

Radiation Hardened and SEE Hardened 3V to 13.2V, 6A Buck Regulator

ISL70003SEH

The ISL70003SEH is a radiation and SEE hardened synchronous buck regulator capable of operating over an input voltage range of 3.0V to 13.2V. With integrated MOSFETs, this highly efficient single chip power solution provides a tightly regulated output voltage that is externally adjustable from 0.6V to ~90% of the input voltage. Continuous output load current capability is 6A for $T_J \leq +125^\circ\text{C}$ and 3A for $T_J \leq +150^\circ\text{C}$.

The ISL70003SEH uses voltage mode control architecture with feed-forward and switches at a selectable frequency of 500kHz or 300kHz. Loop compensation is externally adjustable to allow for an optimum balance between stability and output dynamic performance. The internal synchronous power switches are optimized for high efficiency and excellent thermal performance.

The chip features two logic-level disable inputs that can be used to inhibit pulses on the phase (LXx) pins in order to maximize efficiency based on the load current. The ISL70003SEH also supports DDR applications and contains a buffer amplifier for generating the V_{REF} voltage.

High integration, best in class radiation performance and a feature filled design make the ISL70003SEH an ideal choice to power many of today's small form factor applications.

Applications

- FPGA, CPLD, DSP, CPU core and I/O supply voltages
- DDR memory supply voltages
- Low-voltage, high-density distributed power systems

Related Literature

- [AN1897](#), ISL70003SEHEV1Z Evaluation Board
- [AN1915](#), ISL70003SEH iSim:PE Model
- [AN1913](#), Single Event Effects Testing of the ISL70003SEH, 3V to 13.2V, 6A Synchronous Buck Regulator
- [AN1924](#), Total Dose Testing of the ISL70003SEH Radiation Hardened Point Of Load Regulator

Features

- Acceptance tested to 50krad(Si) (LDR) wafer-by-wafer
- $\pm 1\%$ reference voltage over line, temperature and radiation
- Integrated MOSFETs 31m Ω PFET/21m Ω NFET
 - 95% peak efficiency
- Externally adjustable loop compensation
- Supports DDR applications (V_{TT} tracks $V_{DDQ}/2$)
 - Buffer amplifier for generating V_{REF} voltage
 - 3A current sinking capability
- Grounded lid eliminates charge build up
- IMON pin for output current monitoring
- Adjustable analog soft-start
- Diode emulation for increased efficiency at light loads
- 500kHz or 300kHz operating frequency synch wording
- Monotonic start-up into prebiased load
- Full military temperature range operation
 - $T_A = -55^\circ\text{C}$ to $+125^\circ\text{C}$
 - $T_J = -55^\circ\text{C}$ to $+150^\circ\text{C}$
- Radiation tolerance
 - High dose rate (50-300rad(Si)/s) 100krad(Si)
 - Low dose rate (0.01rad(Si)/s) 100krad(Si)*
 - * Limit established by characterization.
- SEE hardness
 - SEB and SEL LET_{TH} 86.4MeV \cdot cm²/mg
 - SET at LET 86.4MeV \cdot cm²/mg $< \pm 3\%$ ΔV_{OUT}
 - SEFI LET_{TH} 60MeV \cdot cm²/mg
- Electrically screened to DLA SMD [5962-14203](#)

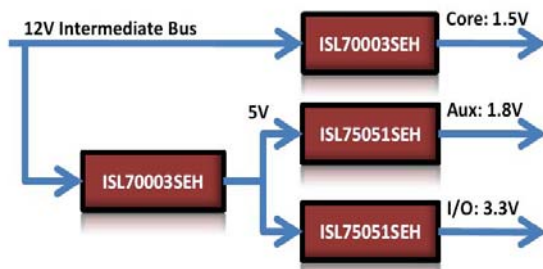

FIGURE 1. POWER DISTRIBUTION SOLUTION FOR RAD HARD LOW POWER FPGA's

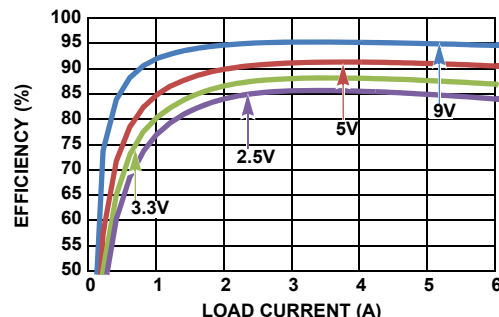

FIGURE 2. EFFICIENCY vs LOAD, $V_{IN} = 12\text{V}$, $f_{SW} = 300\text{kHz}$ ALL OUTPUTS ACTIVE

Table of Contents

Functional Block Diagram	3
Ordering Information	3
Pin Configuration	4
Pin Descriptions	5
Typical Application Schematics	7
Absolute Maximum Ratings	9
Thermal Information	9
Recommended Operating Conditions	9
Electrical Specifications	9
Typical Performance Curves	12
Functional Description	17
Power Blocks	17
Initialization	17
Enable	17
Power on Reset	17
Soft-Start	18
Power-Good	18
Fault Monitoring and Protection	18
Undervoltage and Overvoltage Monitor	18
Undervoltage Protection	19
Overcurrent Protection	19
Application Information	19
Voltage Feed-forward	19
Switching Frequency Selection	20
Synchronization	20
Output Voltage Selection	20
Setting the Overcurrent Protection Level	20
Disabling the Power Blocks	20
IMON Current Sense Output	21
Diode Emulation	21
DDR Application	22
DDR Configuration	22
Derating Current Capability	23
General Design Guide	23
Output Inductor Selection	23
Output Capacitor Selection	23
Input Capacitor Selection	24
Feedback Compensation	25
Modulator Break Frequency Equations	25
Compensation Break Frequency Equations	25
PCB Design	26
PCB Plane Allocation	26
PCB Component Placement	26
LX Connection	26
Thermal Management for Ceramic Package	26
Lead Strain Relief	26
Heatsink Mounting Guidelines	26
Heatsink Electrical Potential	26
Heatsink Mounting Materials	26
Package Characteristics	27
Weight of Packaged Device	27
Lid Characteristics	27
Die Characteristics	27
Die Dimensions	27
Interface Materials	27
Layout Characteristics	27
Step and Repeat	27
Revision History	30
About Intersil	30
Package Outline Drawing	31

ISL70003SEH

Pin Configuration

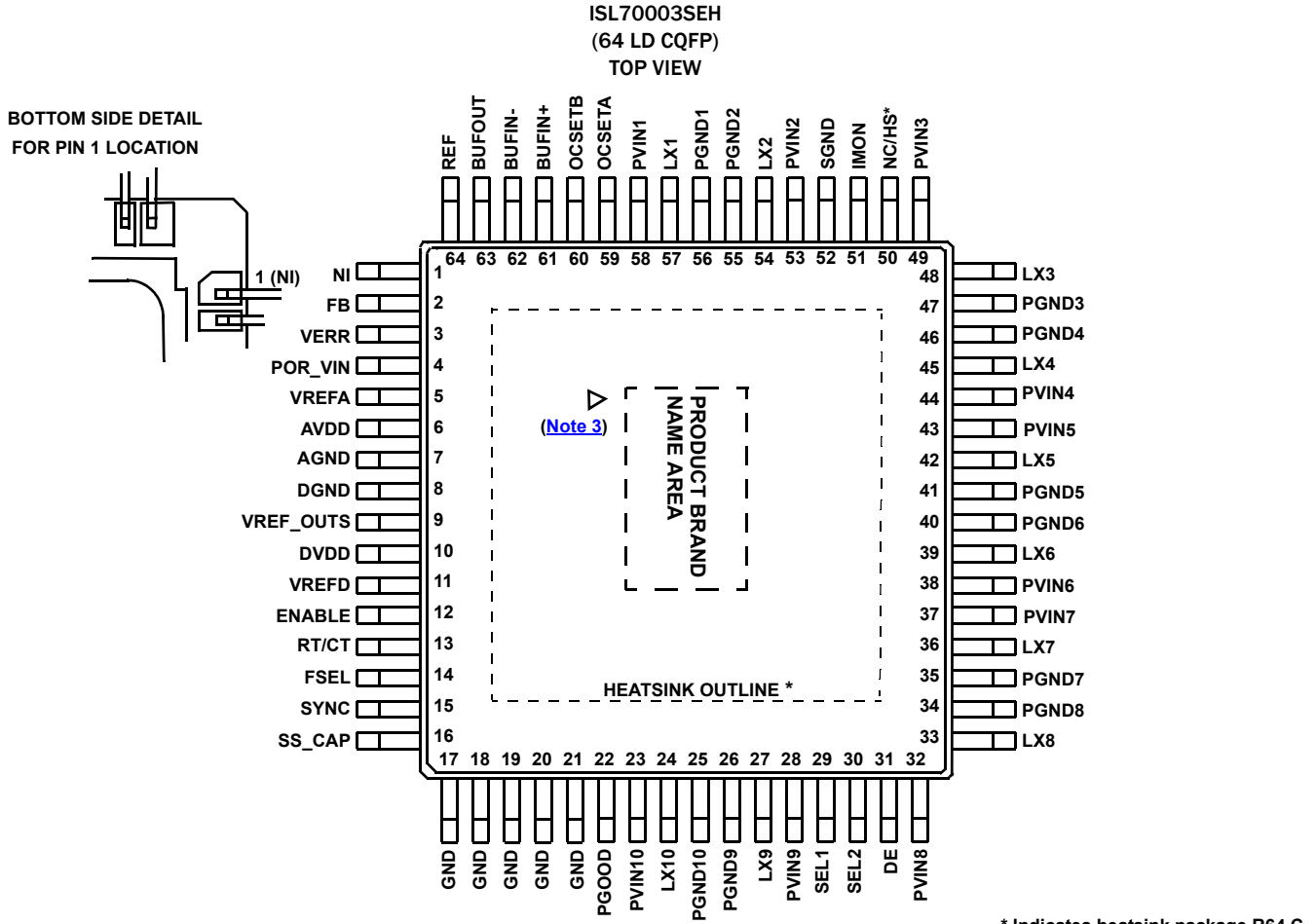

NOTE:

- The ESD triangular mark is indicative of pin #1 location. It is part of the device marking and is placed on the lid in the quadrant where pin #1 is located.

ISL70003SEH

Pin Descriptions

PIN NUMBER	PIN NAME	ESD CIRCUIT	DESCRIPTION
1	NI	1	This pin is the non-inverting input to the internal error amplifier. Connect this pin to the REF pin for typical applications or the BUFOUT pin for DDR memory power applications.
2	FB	1	This pin is the inverting input to the internal error amplifier. An external type III compensation network should be connected between this pin and the VERR pin. The connection between the FB resistor divider and the output inductor should be a Kelvin connection to optimize performance.
3	VERR	1	This pin is the output of the internal error amplifier. An external compensation network should be connected between this pin and the FB pin.
4	POR_VIN	1	This pin is the power-on reset input to the IC. This is a comparator-type input with a rising threshold of 0.6V and programmable hysteresis. Driving this pin above 0.6V enables the IC. Bypass this pin to AGND with a 10nF ceramic capacitor to mitigate SEE.
5	VREFA	3	This pin is the output of the internal linear regulator and the bias supply input to the internal analog control circuitry. Locally filter this pin to AGND using a 0.47µF ceramic capacitor as close as possible to the IC.
6	AVDD	5	This pin provides the supply for internal linear regulator of the ISL70003SEH. The supply to AVDD should be locally bypassed using a ceramic capacitor. Tie AVDD to the PVINx pins.
7	AGND	1, 3	This pin is the analog ground associated with the internal analog control circuitry. Connect this pin directly to the PCB ground plane.
8	DGND	2, 4	This pin is the ground associated with the internal digital control circuitry. Connect this pin directly to the PCB ground plane.
9	VREF_OUTS	4	This pin is the output of the internal linear regulator and the supply input to the internal reference circuit. Locally filter this pin to AGND using a 0.47µF ceramic capacitor as close as possible to the IC.
10	DVDD	6	This pin provides the supply for the internal linear regulator of the ISL70003SEH. The supply to DVDD should be locally bypassed using a ceramic capacitor. Tie DVDD to the PVINx pin.
11	VREFD	4	This pin is the output of the internal linear regulator and the bias supply input to the internal digital control circuitry. Locally filter this pin to DGND using a 0.47µF ceramic capacitor as close as possible to the IC.
12	ENABLE	6	This pin is a logic-level enable input. Pulling this pin low powers down the chip by placing it into a very low power sleep mode.
13	RT/CT	6	A resistor to VIN and a capacitor to GND provide feed-forward to keep a constant modulator gain of 4.8 as VIN varies.
14	FSEL	2	This pin is the oscillator frequency select input. Tie this pin to 5V to select a 300kHz nominal oscillator frequency. Tie this pin to the PCB ground plane to select a 500kHz nominal oscillator frequency.
15	SYNC	2	This pin is the frequency synchronization input to the IC. This pin should be tied to GND to free-run from the internal oscillator or connected to an external clock for external frequency synchronization.
16	SS_CAP	2	This pin is the soft-start input. Connect a ceramic capacitor from this pin to the PCB ground plane to set the soft-start output ramp time in accordance with Equation 1 : $t_{SS} = C_{SS} \cdot V_{REF} / I_{SS} \quad (\text{EQ. 1})$ where: t_{SS} = soft-start output ramp time C_{SS} = soft-start capacitance V_{REF} = reference voltage (0.6V typical) I_{SS} = soft-start charging current (23µA typical) Soft-start time is adjustable from approximately 2ms to 200ms. The range of the soft-start capacitor should be 82nF to 8.2µF, inclusive.
17, 18, 19, 20, 21	GND	2	Connect this pin to the PCB ground plane.
22	PGOOD	6	This pin is the power-good output. This pin is an open-drain logic output that is pulled to DGND when the output voltage is outside a ±11% typical regulation window. This pin can be pulled up to any voltage from 0V to 13.2V, independent of the supply voltage. A nominal 1kΩ to 10kΩ pull-up resistor is recommended. Bypass this pin to the PCB ground plane with a 10nF ceramic capacitor to mitigate SEE.

ISL70003SEH

Pin Descriptions (Continued)

PIN NUMBER	PIN NAME	ESD CIRCUIT	DESCRIPTION
23, 28, 32, 37, 38, 43, 44, 49, 53, 58	PVINx	7	These pins are the power supply inputs to the corresponding internal power blocks. These pins must be connected to a common power supply rail, which should fall in the range of 3V to 13.2V. Bypass these pins directly to PGNDx with ceramic capacitors located as close as possible to the IC. When sinking current or at a no load condition, the inductor valley current will be negative. During any time when the inductor valley current is negative and the ISL70003 is exposed to a heavy ion environment, the abs max PVIN voltage must be $\leq 13.7V$.
29	SEL1	2	This pin is a logic-level disable (high) input working in conjunction with SEL2. These pins form a two-bit logic input that set the number of active power blocks. This allows the ISL70003SEH current capability to be tailored to the load current level the application requires and achieve the highest possible efficiency.
30	SEL2	2	This pin is a logic-level disable input. Pulling this pin high inhibits pulses on the Lx outputs. See description of Pin 29, SEL1, for more information.
31	DE	2	The DE pin enables or disables Diode Emulation. When it is HIGH, diode emulation is allowed. Otherwise, continuous conduction mode is forced.
24, 27, 33, 36, 39, 42, 45, 48, 54, 57	Lx		These pins are the switch node connections to the internal power blocks and should be connected to the output filter inductor. Internally, these pins are connected to the synchronous MOSFET power switches.
50	NC/HS	N/A	This is a No Connect pin that is not connected to anything internally. In the R64.C package (heatsink option) this pin is electrically connected to the heatsink on the underside of the package. Connect this pin and/or the heatsink to a thermal plane.
51	IMON	1	IMON is a current source output that is proportional to the sensed current through the regulator. If not used it is recommended to tie IMON to VREFA. It is also acceptable to tie IMON to GND through a resistor.
52	SGND	1	This pin is connected to an internal metal trace that serves as a noise shield. Connect this pin to the PCB ground plane.
25, 26, 34, 35, 40, 41, 46, 47, 55, 56	PGNDx	7	These pins are the power grounds associated with the corresponding internal power blocks. Connect these pins directly to the PCB ground plane. These pins should also connect to the negative terminals of the input and output capacitors. The package lid is internally connected to PGNDx
59	OCSETA	3	This pin is the redundant output overcurrent set input. Connect a resistor from this pin to the PCB ground plane to set the output overcurrent threshold.
60	OCSETB	3	This pin is the primary output overcurrent set input. Connect a resistor from this pin to the PCB ground plane to set the output overcurrent threshold.
61	BUFIN+	1	This pin is the input to the internal unity gain buffer amplifier. For DDR memory power applications, connect the VTT voltage to this pin.
62	BUFIN-	1	This pin is the inverting input to the buffer amplifier. For DDR memory power applications, connect BUFOUT to this pin. Bypass this pin to the PCB ground plane with a 0.1 μ F ceramic capacitor.
63	BUFOUT	3	This pin is the output of the buffer amplifier. In DDR power applications, connect this pin to the reference input of the DDR memory. The buffer needs a minimum of 1.0 μ F load capacitor for stability.
64	REF	1	This pin is the output of the internal reference voltage. Bypass this pin to the PCB ground plane with a 220nF ceramic capacitor located as close as possible to the IC. The bypass capacitor is needed to mitigate SEE.

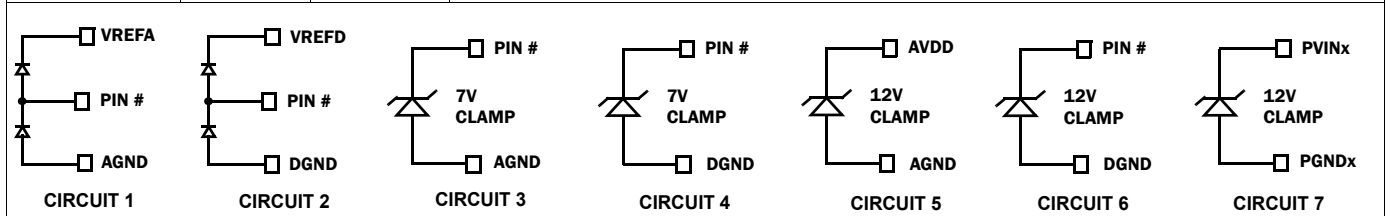

ISL70003SEH

Typical Application Schematics

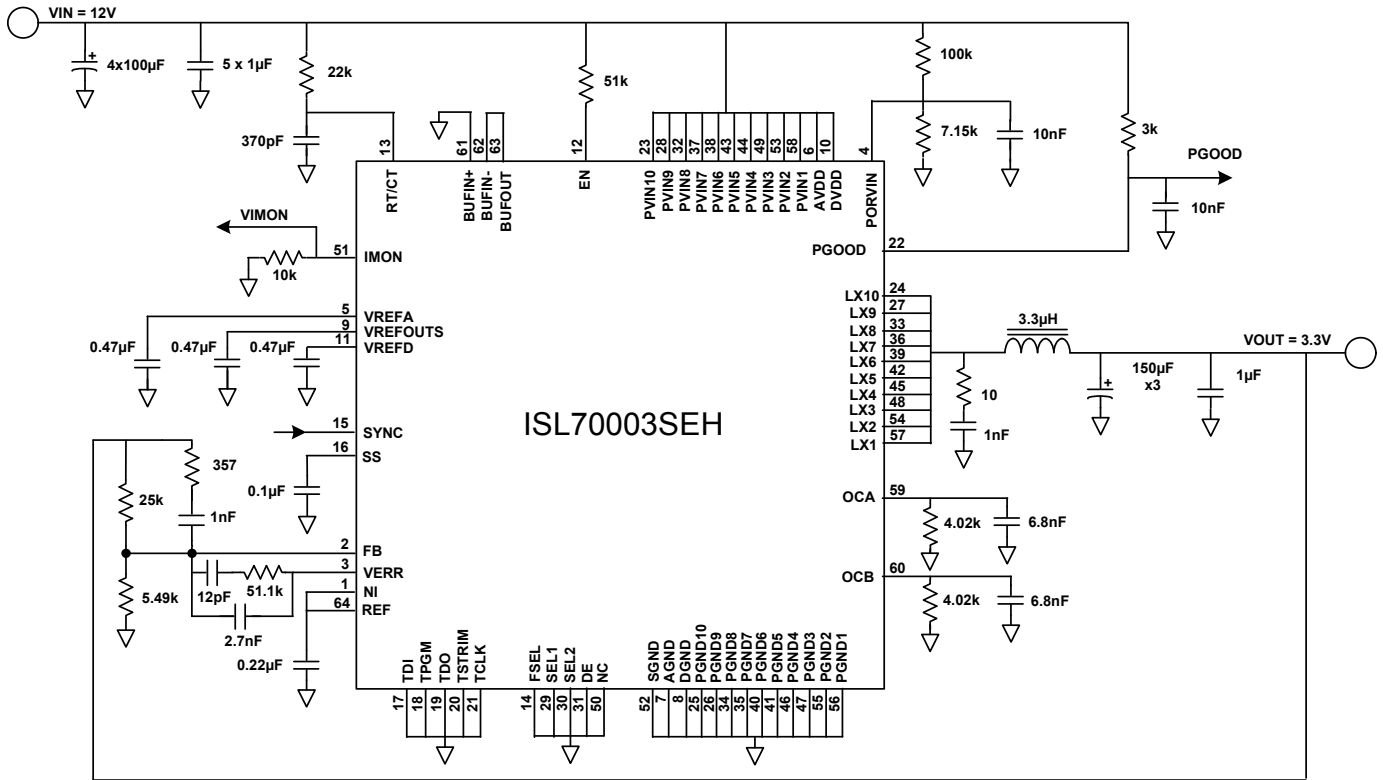

FIGURE 3. ISL70003SEH SINGLE UNIT OPERATION

ISL70003SEH

Absolute Maximum Ratings

LXx, PVINx	PGNDx - 0.3V to PGNDx + 16V
LXx, PVINx (Note 4)	PGNDx - 0.3V to PGNDx + 14.7V
LXx, PVINx (Note 5)	PGNDx - 0.3V to PGNDx + 13.7V
AVDD - AGND, DVDD - DGND	PVINx to -0.3V
VREFA	GNDx - 0.3V to GNDx + 5.5V
VREFD, VREF_OUTS	GNDD - 0.3V to GNDD + 5.5V
Signal Pins (Note 10)	GNDx - 0.3V to VREFA + 0.3V
Digital Control Pins (Note 11)	GNDD - 0.3V to VREFD+ 0.3V
SS	DGND - 0.3V to DGND + 2.5V
PGOOD	GNDD - 0.3V to DVDD
RTCT	GNDD - 0.3V to DVDD
ESD Rating	
Human Body Model (Tested per MIL-STD-883 TM3015.7)	2kV
Machine Model (Tested per JESD22-A115-A)	200V
Charge Device Model (Tested per JESD22-C101D)	750V

Thermal Information

Thermal Resistance (Typical)	θ_{JA} (°C/W)	θ_{JC} (°C/W)
CQFP Package R64.A (Notes 6, 7)	34	1.5
CQFP Package R64.C (Notes 8, 9)	17	0.7
Maximum Junction Temperature	+150°C	
Storage Temperature Range	-65°C to +150°C	
Pb-Free Reflow Profile	see TB493	

Recommended Operating Conditions

Temperature	-55°C to +125°C
PVINx, AVDD, DVDD	3.3V ±10% to 12V ±10%

CAUTION: Do not operate at or near the maximum ratings listed for extended periods of time. Exposure to such conditions may adversely impact product reliability and result in failures not covered by warranty.

NOTES:

- For operation in a heavy ion environment at LET = 86.4 MeV • cm²/mg at 125°C (T_C) and sourcing 7A load current.
- For operation in a heavy ion environment at LET = 86.4 MeV • cm²/mg at 125°C (T_C) with any negative inductor current to sinking -4A load current.
- θ_{JA} is measured with the component mounted on a high effective thermal conductivity test board in free air. See Tech Brief [TB379](#) for details.
- For θ_{JC} , the “case temp” location is the center of the package underside.
- θ_{JA} is measured in free air with the component mounted on a high effective thermal conductivity test board with “direct attach” features. See Tech Brief [TB379](#).
- For θ_{JC} , the “case temp” location is the center of the exposed metal heatsink on the package underside.
- POR_VIN, FB, NI, VERR, OCSETA, OCSETB, BUFOUT, BUFIN-, BUFIN+, IMON and REF pins.
- FSEL, EN, SYNC, SEL1, SEL2, and DE pins.

Electrical Specifications

Unless otherwise noted, V_{IN} = AVDD = DVDD = PVINx = EN = 3V - 13.2V; GND = AGND = DGND = PGNDx = GNDx = 0V; POR_VIN = FB = 0.65V; SYNC = LXx = Open Circuit; PGOOD is pulled up to VREFD with a 3k resistor; REF is bypassed to GND with a 220nF capacitor; SS is bypassed to GND with a 100nF capacitor; I_{OUT} = 0A; T_A = T_J = +25°C. (Note 4). **Boldface limits apply across the operating temperature range, -55°C to +125°C; over a total ionizing dose of 100krad(Si) with exposure at a high dose rate of 50 - 300rad(Si)/s; or over a total ionizing dose of 50krad(Si) with exposure at a low dose rate of <10mrad(Si)/s.**

PARAMETER	TEST CONDITIONS	MIN (Note 15)	TYP	MAX (Note 15)	UNITS
POWER SUPPLY					
Operating Supply Current	PVINx = 13.2V, FSEL = 1		80	125	mA
	PVINx = 13.2V, FSEL = 0		80	125	mA
	PVINx = 3.0V, FSEL = 1		30	60	mA
	PVINx = 3.0V, FSEL = 0		30	60	mA
Standby Supply Current	PVINx = 13.2V, SEL1 = SEL2 = GND, FSEL = 1		20	30	mA
	PVINx = 13.2V, SEL1 = SEL2 = GND, FSEL = 0		20	30	mA
	PVINx = 3.0V, SEL1 = SEL2 = GND, FSEL = 1		10	15	mA
	PVINx = 3.0V, SEL1 = SEL2 = GND, FSEL = 0		10	15	mA
Shutdown Supply Current	PVINx = 13.2V, EN = GND		1.5	3.0	mA
	PVINx = 3.0V, EN = GND		0.4	1.0	mA
LINEAR REGULATORS					
Output Voltage	AVDD, DVDD = 13.2V	4.5	5.0	5.5	V
Current Limit	AVDD, DVDD = 13.2V	50		190	mA

ISL70003SEH

Electrical Specifications Unless otherwise noted, $V_{IN} = AVDD = DVDD = PVINx = EN = 3V - 13.2V$; $GND = AGND = DGND = PGNDx = GNDx = 0V$; $POR_V_{IN} = FB = 0.65V$; $SYNC = LX = \text{Open Circuit}$; $PGOOD$ is pulled up to $VREFD$ with a 3k resistor; REF is bypassed to GND with a 220nF capacitor; SS is bypassed to GND with a 100nF capacitor; $I_{OUT} = 0A$; $T_A = T_J = +25^\circ C$. (Note 4). **Boldface limits apply across the operating temperature range, $-55^\circ C$ to $+125^\circ C$; over a total ionizing dose of 100krad(SI) with exposure at a high dose rate of 50 - 300rad(SI)/s; or over a total ionizing dose of 50krad(SI) with exposure at a low dose rate of $<10\text{mrad(SI)/s}$.** (Continued)

PARAMETER	TEST CONDITIONS	MIN (Note 15)	TYP	MAX (Note 15)	UNITS
POWER-ON RESET					
POR Pin Input Voltage		0.56	0.6	0.64	V
POR Sink Current		9.6	12	14.4	μA
ENABLE					
Enable VIH Voltage		2			V
Enable VIL Voltage				0.8	V
Enable (EN) Leakage	EN = 4.5V		1.0	10	μA
SELECT PHASE					
SEL 1, 2 VIH Voltage		2			V
SEL 1, 2 VIL Voltage				0.8	V
SEL 1, 2 Leakage Current	SEL1, 2 = VREFD		1.0	10	μA
PWM CONTROL LOGIC					
Switching Frequency	FSEL = 1	255	300	345	kHz
	FSEL = 0	425	500	575	kHz
Minimum On Time	SS = GND (Note 14)		250	320	ns
Minimum On Time	(Note 14)		160	220	ns
Minimum Off Time	(Note 14)		200	270	ns
Modulator Gain ($V_{IN} / \Delta V_{OSC}$)	$R_T = 22k\Omega$, $C_T = 370pF$, FSEL = 0		5		V/V
	$R_T = 36k\Omega$, $C_T = 370pF$, FSEL = 1		4.8		V/V
External Synchronization Frequency Range	FSEL = 1, $PV_{INx} = 3.0V$	255	300	345	kHz
	FSEL = 0, $PV_{INx} = 3.0V$	425	500	575	kHz
SYNC VIH Voltage		2			V
SYNC VIL Voltage				0.8	V
Synchronization Input Leakage Current	SYNC = VREFD		1.0	4	μA
SOFT-START					
Soft-start Source Current	SS = GND	20	23	27	μA
Soft-start Discharge ON-Resistance			3.0	6.0	Ω
Soft-start Discharge Time	(Note 14)		256		Clock Cycles
REFERENCE VOLTAGE					
Reference Voltage Tolerance	VREF + Error Amplifier V_{IO}	0.594	0.6	0.606	V
ERROR AMPLIFIER					
DC Gain	(Note 14)		80		dB
Gain-bandwidth Product	(Note 14)		7		MHz
Maximum Output Voltage	$V_{IN} = 5.5V$	3.5	4.2		V
Slew Rate	(Note 14)		8.5		V/ μs
Feedback (FB) Input Leakage Current	$V_{FB} = 0.6V$, $PV_{INx} = 13.2V$			250	nA
Offset Voltage (V_{IO})		-3	0	3	mV

ISL70003SEH

Electrical Specifications Unless otherwise noted, $V_{IN} = AVDD = DVDD = PV_{INx} = EN = 3V - 13.2V$; $GND = AGND = DGND = PGNDx = GNDx = 0V$; $POR_V_{IN} = FB = 0.65V$; $SYNC = LXx = \text{Open Circuit}$; $PGOOD$ is pulled up to V_{REFD} with a 3k resistor; REF is bypassed to GND with a 220nF capacitor; SS is bypassed to GND with a 100nF capacitor; $I_{OUT} = 0A$; $T_A = T_J = +25^\circ C$. (Note 4). **Boldface limits apply across the operating temperature range, $-55^\circ C$ to $+125^\circ C$; over a total ionizing dose of 100krad(SI) with exposure at a high dose rate of 50 - 300rad(SI)/s; or over a total ionizing dose of 50krad(SI) with exposure at a low dose rate of <10mrad(SI)/s. (Continued)**

PARAMETER	TEST CONDITIONS	MIN (Note 15)	TYP	MAX (Note 15)	UNITS
POWER BLOCKS					
Upper Device $r_{DS(ON)}$	$PV_{INx} = 3.0V$	170	420	700	m Ω
	$PV_{INx} = 5.5V$	120	310	600	m Ω
Lower Device $r_{DS(ON)}$	$PV_{INx} = 3.0V$	90	240	455	m Ω
	$PV_{INx} = 5.5V$	60	210	425	m Ω
LXx Output Leakage	$EN = LXx = GND$, Single LXx Output		1	3	μA
	$EN = GND$, $LXx = PV_{INx}$, Single LXx Output		1	3	μA
Dead Time	Within a Single Power Block or between Power Blocks (Note 14)	4			ns
POWER-GOOD SIGNAL					
Rising Threshold	V_{FB} as a % of V_{REF}	107	111	115	%
Rising Hysteresis	V_{FB} as a % of V_{REF}	2	3.5	5	%
Falling Threshold	V_{FB} as a % of V_{REF}	85	89	93	%
Falling Hysteresis	V_{FB} as a % of V_{REF}	2	3.5	5	%
Power-good Drive	$PV_{IN} = 3V$, $PGOOD = 0.4V$, $EN = GND$	7.2			mA
Power-good Leakage	$PV_{IN} = PGOOD = 13.2V$			1	μA
PROTECTION FEATURES					
Undervoltage Protection					
Undervoltage Trip Threshold	V_{FB} as a % of V_{REF} , Test mode	71	75	79	%
Undervoltage Recovery Threshold	V_{FB} as a % of V_{REF} , Test mode	86	90	94	%
Overcurrent Protection					
Overcurrent Accuracy	ROCSETA, $B = 6k\Omega$ ($IOC = 0.6A/LX$) $V_{IN} = 12V$	0.43	0.6	0.77	A/LX
BUFFER AMPLIFIER					
Gain Bandwidth Product	$C_L = 1\mu F$, $I_{SOURCE} = 1mA$, $A_V = 1$, $V_{OUT} = 1.25V$ (Note 14)		200		kHz
Source Current Capability				20	mA
Sink Current Capability		250	400		μA
Offset Voltage		-4	0	4	mV
IMON CURRENT MONITOR					
IMON Sense Time		145	215	300	ns
IMON Output Current Gain	$I_{LOAD} = 1A$ /Power Stage, LXx Off Time >300ns		100		$\mu A/A$
IMON Gain Accuracy	$I_{LOAD} = 1A$ /Power Stage, LXx Off Time >300ns	-14		14	μA

NOTES:

12. Typical values shown are not guaranteed.
13. The 0A to 6A output current range may be reduced by Minimum LXx On Time and Minimum LXx Off Time specifications.
14. Limits established by characterization or analysis and are not production tested.
15. Parameters with MIN and/or MAX limits are 100% tested at $-55^\circ C$, $+25^\circ C$ and $+125^\circ C$, unless otherwise specified.

ISL70003SEH

Typical Performance Curves

Unless otherwise noted, $V_{IN} = 12V$, $V_{OUT} = 3.3V$, $I_{OUT} = 3A$, $f_{SW} = 500kHz$, $C_{IN} = 4 \times 100\mu F + 5 \times 1\mu F$, $L_{OUT} = 3.3\mu H$, $C_{OUT} = 3 \times 150\mu F + 1\mu F$, $T_A = +25^\circ C$, All outputs active.

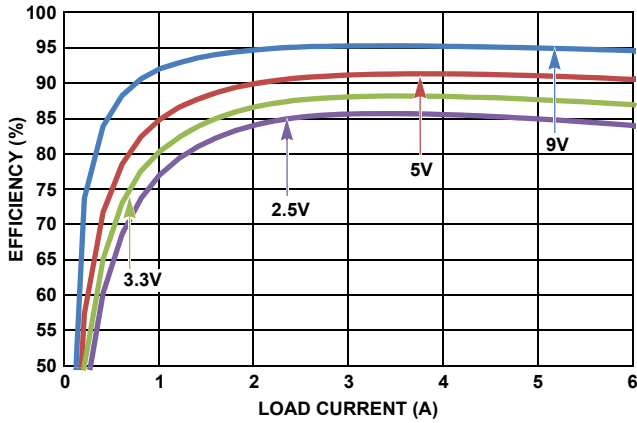

FIGURE 5. EFFICIENCY vs LOAD, $V_{IN} = 12V$, 300kHz

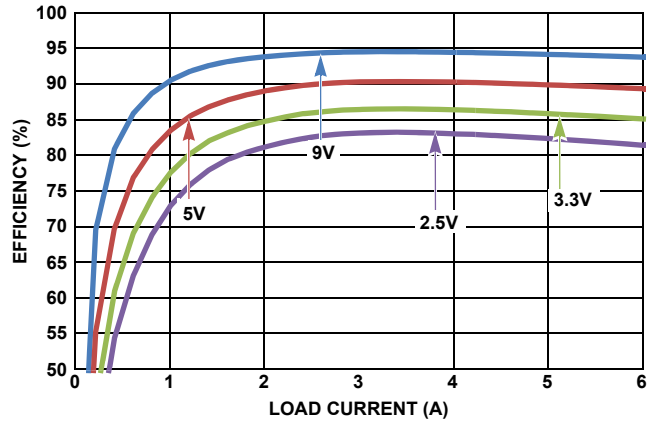

FIGURE 6. EFFICIENCY vs LOAD, $V_{IN} = 12V$, 500kHz

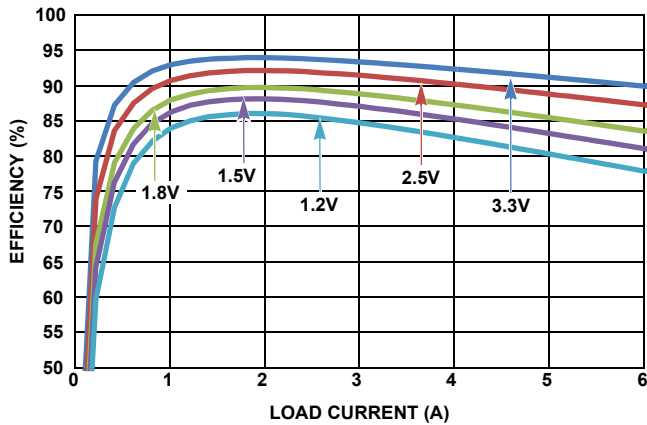

FIGURE 7. EFFICIENCY vs LOAD, $V_{IN} = 5V$, 300kHz

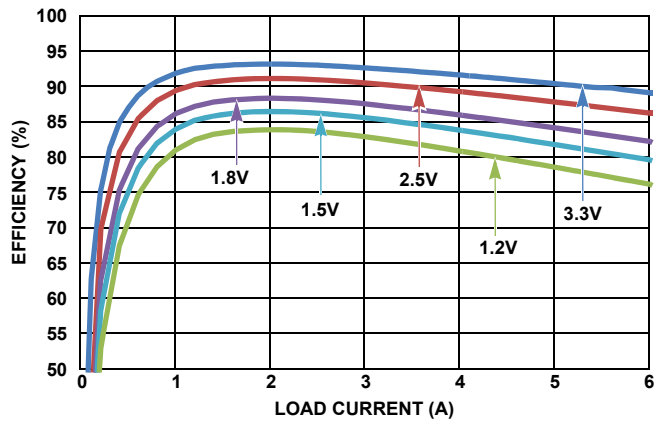

FIGURE 8. EFFICIENCY vs LOAD, $V_{IN} = 5V$, 500kHz

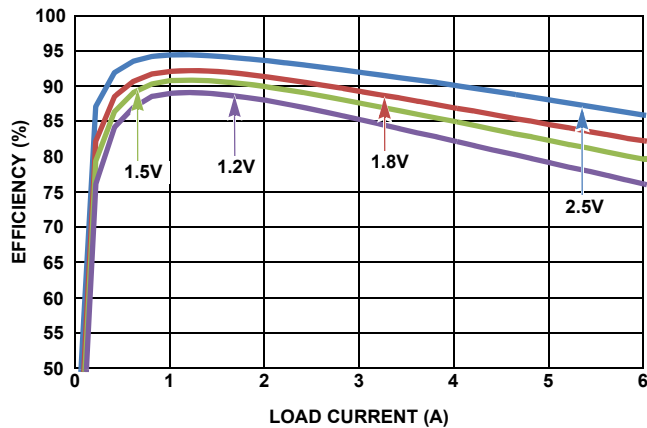

FIGURE 9. EFFICIENCY vs LOAD, $V_{IN} = 3.3V$, 300kHz

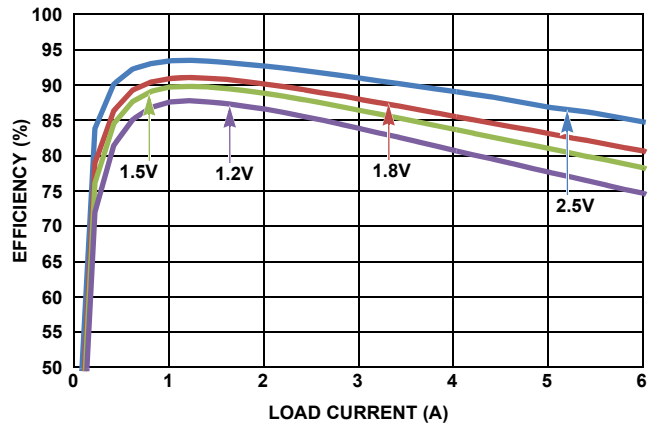

FIGURE 10. EFFICIENCY vs LOAD, $V_{IN} = 3.3V$, 500kHz

Typical Performance Curves

Unless otherwise noted, $V_{IN} = 12V$, $V_{OUT} = 3.3V$, $I_{OUT} = 3A$, $f_{SW} = 500kHz$, $C_{IN} = 4 \times 100\mu F + 5 \times 1\mu F$, $L_{OUT} = 3.3\mu H$, $C_{OUT} = 3 \times 150\mu F + 1\mu F$, $T_A = +25^\circ C$, All outputs active. (Continued)

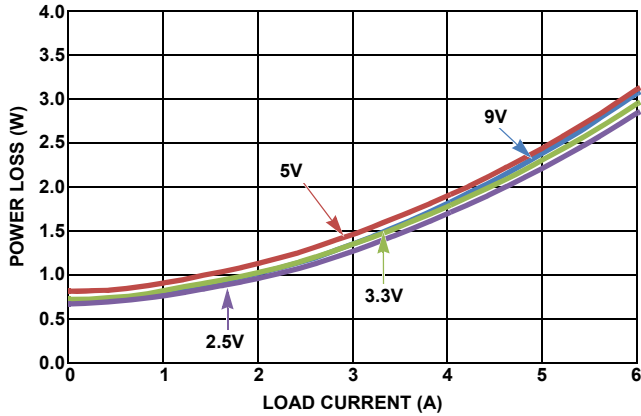

FIGURE 11. POWER LOSS, $V_{IN} = 12V$, 300kHz

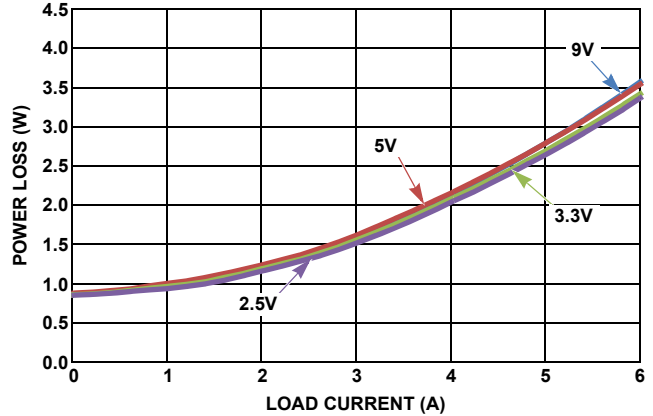

FIGURE 12. POWER LOSS, $V_{IN} = 12V$, 500kHz

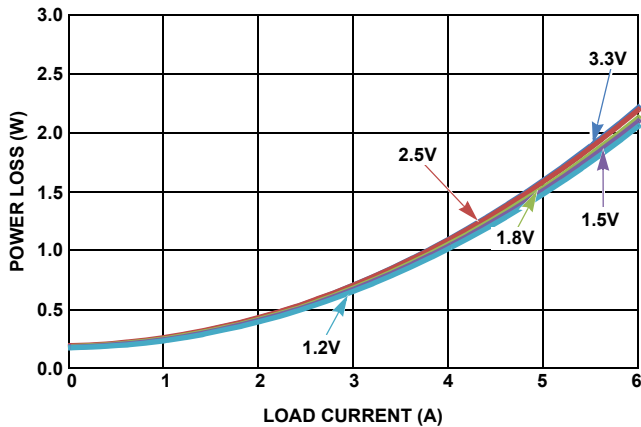

FIGURE 13. POWER LOSS, $V_{IN} = 5V$, 300kHz

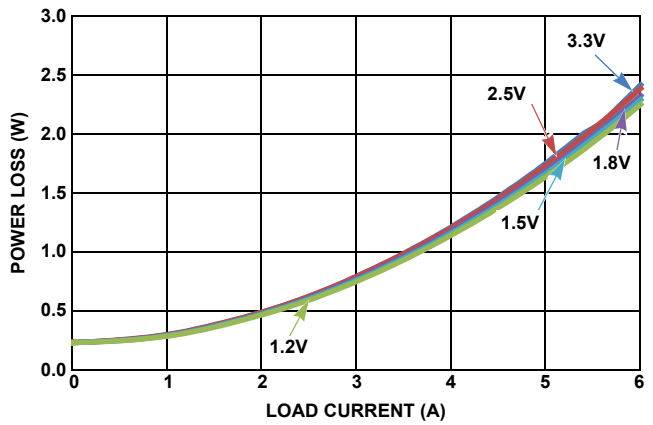

FIGURE 14. POWER LOSS, $V_{IN} = 5V$, 500kHz

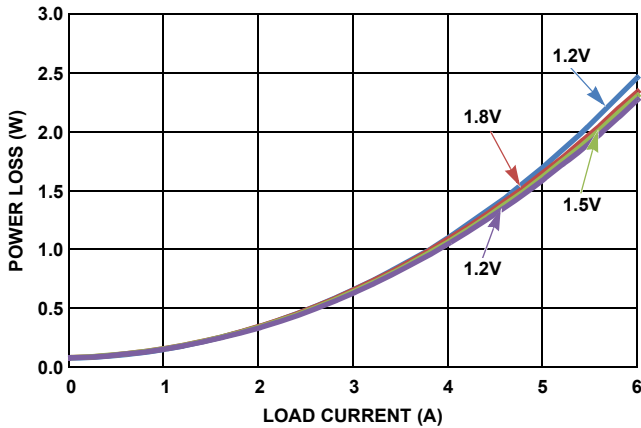

FIGURE 15. POWER LOSS, $V_{IN} = 3.3V$, 300kHz

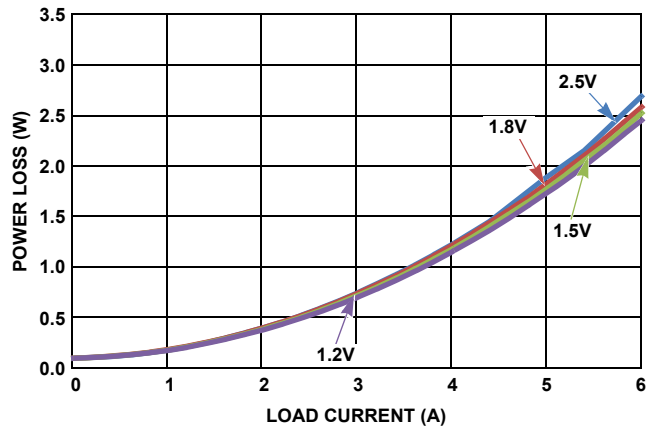

FIGURE 16. POWER LOSS, $V_{IN} = 3.3V$, 500kHz

ISL70003SEH

Typical Performance Curves Unless otherwise noted, $V_{IN} = 12V$, $V_{OUT} = 3.3V$, $I_{OUT} = 3A$, $f_{SW} = 500kHz$, $C_{IN} = 4 \times 100\mu F + 5 \times 1\mu F$, $L_{OUT} = 3.3\mu H$, $C_{OUT} = 3 \times 150\mu F + 1\mu F$, $T_A = +25^\circ C$, All outputs active. **(Continued)**

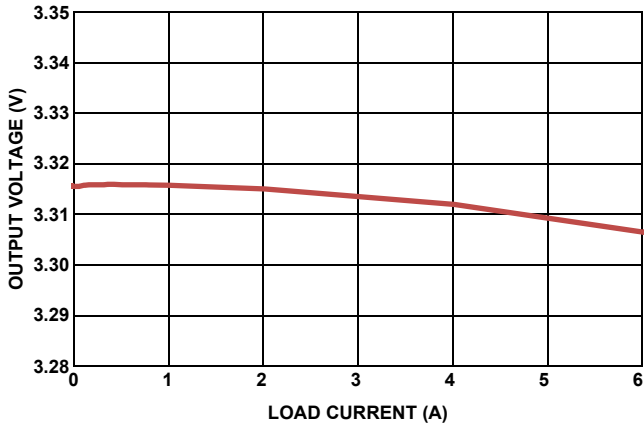

FIGURE 17. LOAD REGULATION

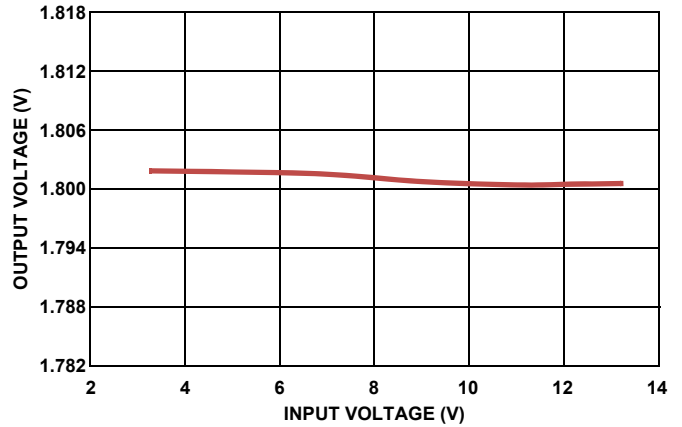

FIGURE 18. LINE REGULATION, $V_{OUT} = 1.8V$, LOAD = 3A

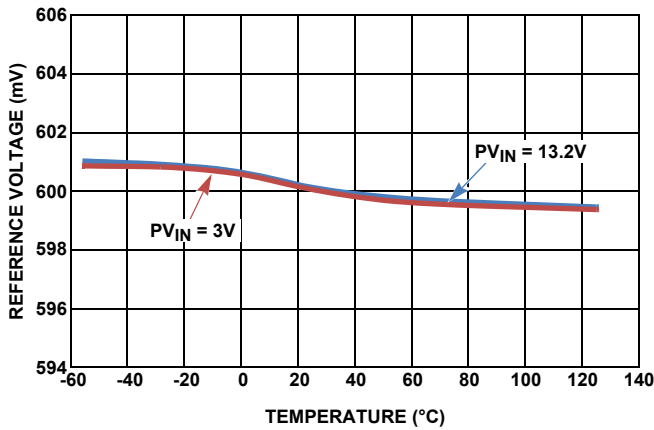

FIGURE 19. REFERENCE VOLTAGE vs TEMPERATURE

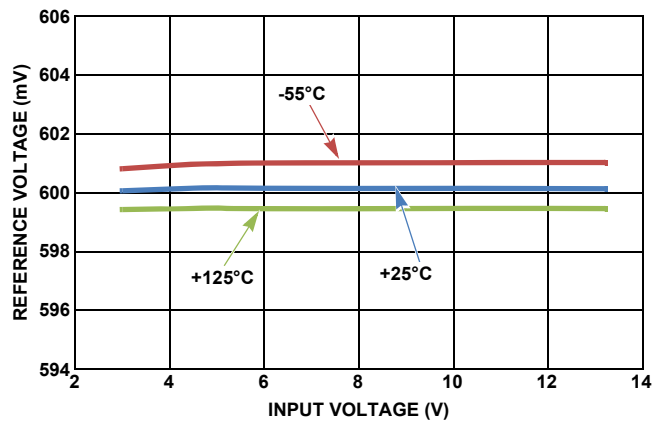

FIGURE 20. REFERENCE VOLTAGE vs V_{IN}

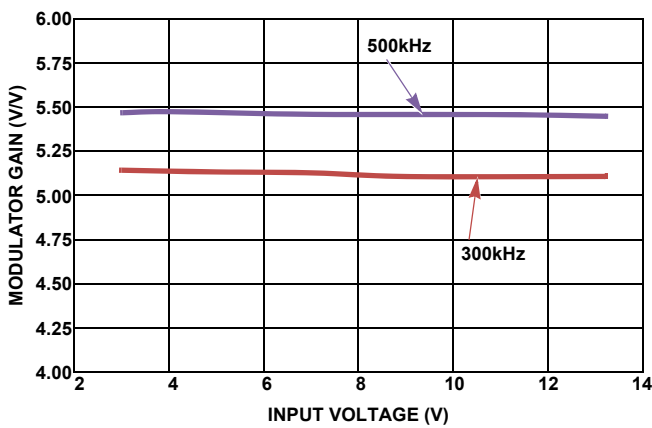

FIGURE 21. MODULATOR GAIN vs V_{IN}

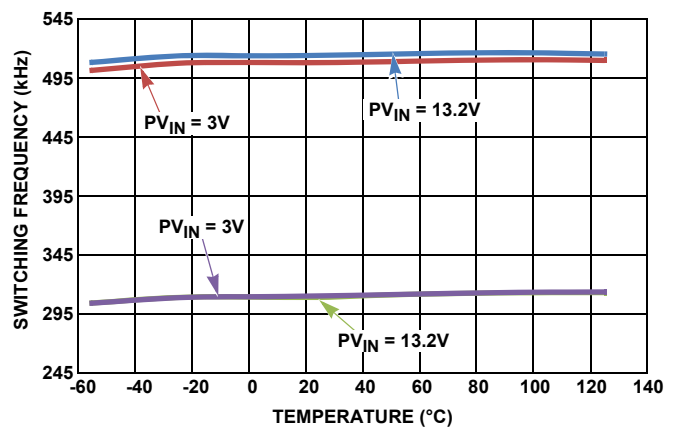

FIGURE 22. SWITCHING FREQUENCY vs TEMPERATURE

ISL70003SEH

Typical Performance Curves Unless otherwise noted, $V_{IN} = 12V$, $V_{OUT} = 3.3V$, $I_{OUT} = 3A$, $f_{SW} = 500kHz$, $C_{IN} = 4 \times 100\mu F + 5 \times 1\mu F$, $L_{OUT} = 3.3\mu H$, $C_{OUT} = 3 \times 150\mu F + 1\mu F$, $T_A = +25^\circ C$, All outputs active. **(Continued)**

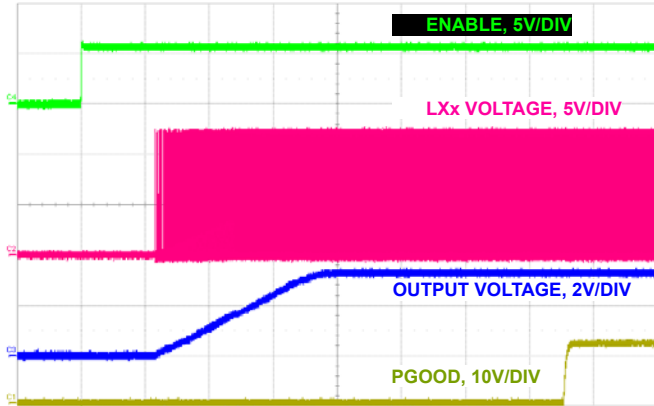

FIGURE 23. MONOTONIC SOFT-START WITH NO LOAD, CCM

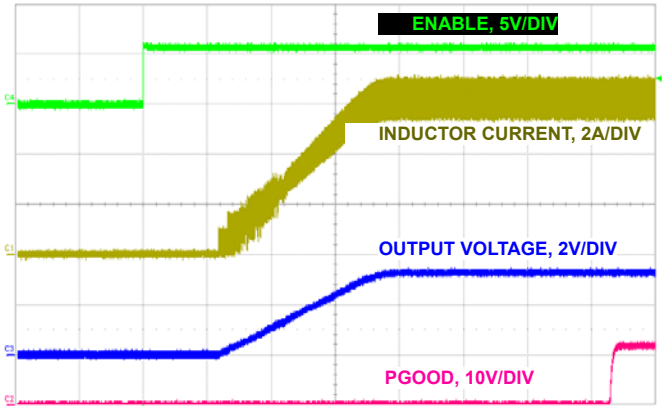

FIGURE 24. MONOTONIC SOFT-START WITH 6A LOAD, CCM

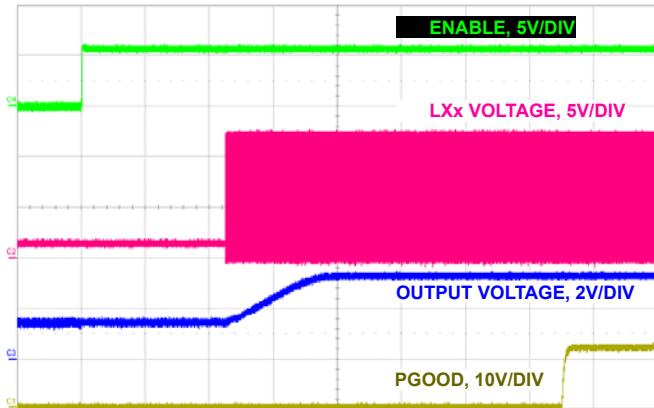

FIGURE 25. MONOTONIC SOFT-START WITH 1.5V PREBIASED LOAD

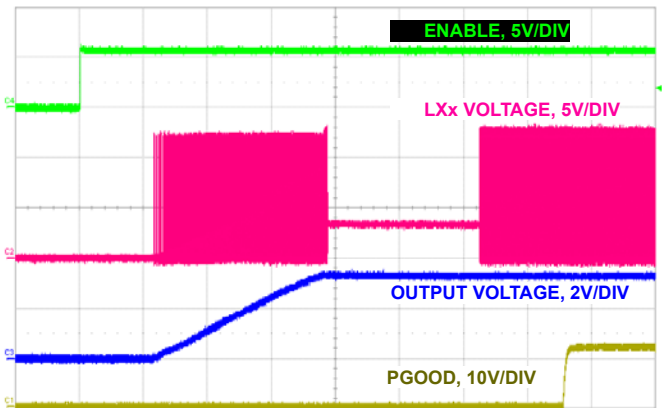

FIGURE 26. MONOTONIC SOFT-START WITH NO LOAD, DEM

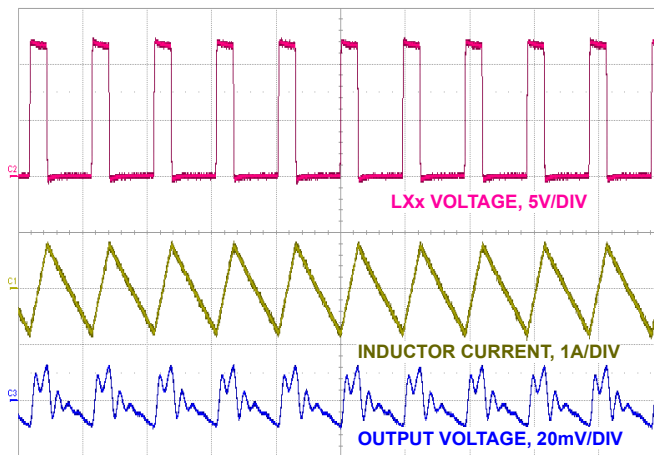

FIGURE 27. STEADY STATE OPERATION NO LOAD, CCM

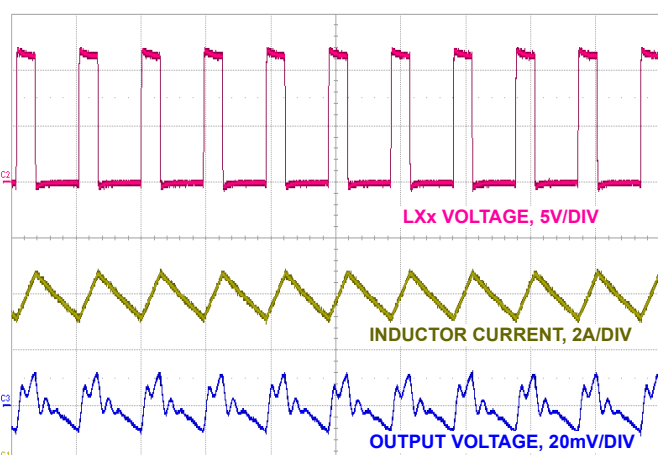

FIGURE 28. STEADY STATE OPERATION FULL LOAD, CCM

Typical Performance Curves

Unless otherwise noted, $V_{IN} = 12V$, $V_{OUT} = 3.3V$, $I_{OUT} = 3A$, $f_{SW} = 500kHz$, $C_{IN} = 4 \times 100\mu F + 5 \times 1\mu F$, $L_{OUT} = 3.3\mu H$, $C_{OUT} = 3 \times 150\mu F + 1\mu F$, $T_A = +25^\circ C$, All outputs active. **(Continued)**

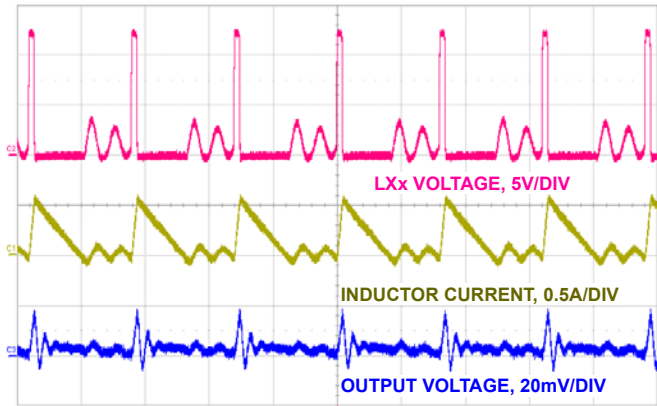

FIGURE 29. DIODE EMULATION OPERATION, $V_{OUT} = 1.2V$, 125mA LOAD

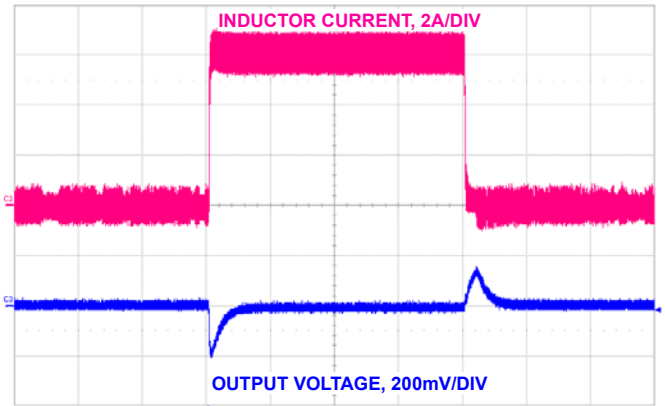

FIGURE 30. 6A LOAD TRANSIENT RESPONSE, DIODE EMULATION

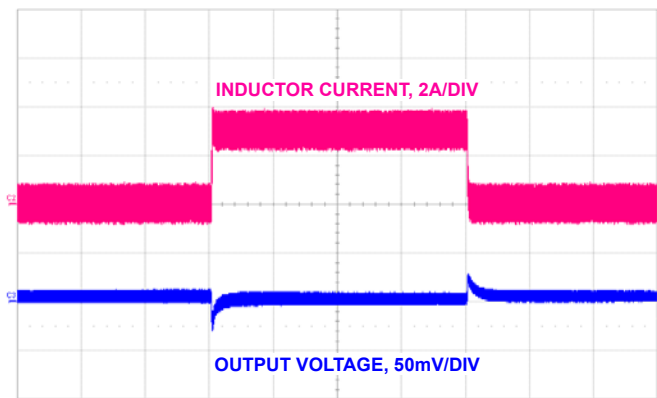

FIGURE 31. 3A LOAD TRANSIENT RESPONSE

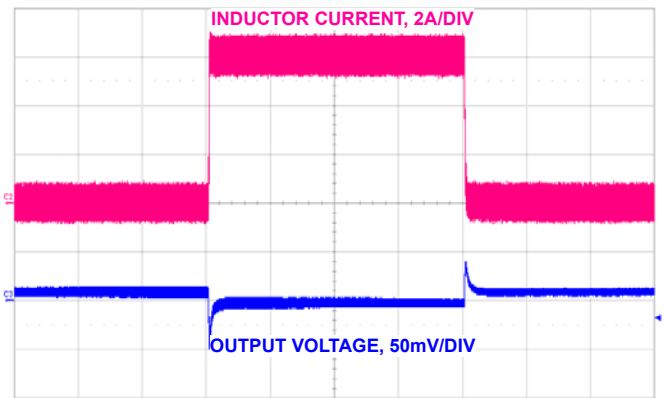

FIGURE 32. 6A LOAD TRANSIENT RESPONSE

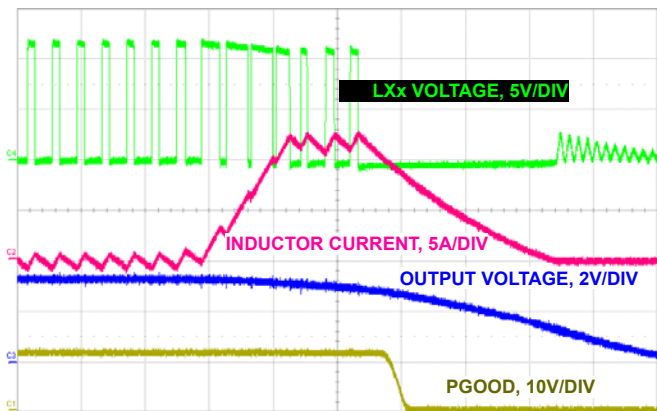

FIGURE 33. OVERCURRENT RESPONSE

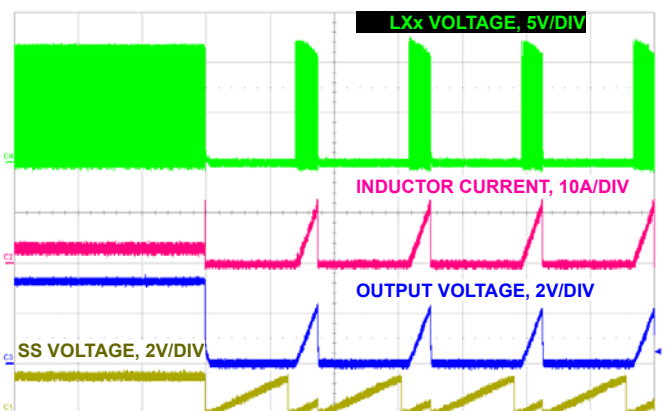
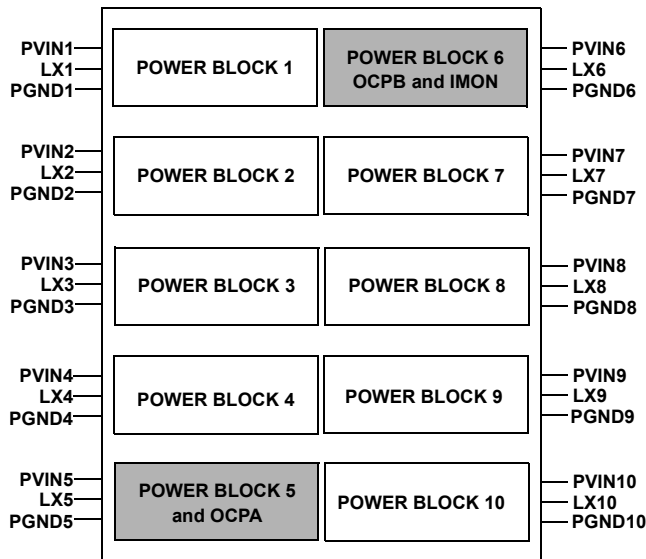

FIGURE 34. HICCUP RESPONSE IN OCP

Functional Description

The ISL70003SEH is a monolithic synchronous buck regulator IC with integrated power MOSFETs. The device utilizes voltage-mode control with feed-forward and switches at a nominal frequency of 500kHz or 300kHz. It is fabricated on a 0.6µm BiCMOS junction isolated process optimized for power management applications. With this chip and a handful of external components, a complete synchronous buck DC/DC converter can be readily implemented. The converter accepts an input voltage ranging from 3V to 13.2V and provides a tightly regulated output voltage ranging from 0.6V to ~90% of the input voltage at output currents ranging from 0A to 6A. Typical applications include Point Of Load (POL) regulation for FPGAs, CPLDs, DSPs, DDR memory and microprocessors.

Power Blocks



Note: Shaded blocks indicate pilot current and current sensors.

FIGURE 35. POWER BLOCK DIAGRAM

The power output stage of the regulator consists of ten power blocks that are paralleled to provide full 6A output current capability at $T_J = +125^\circ\text{C}$. The block diagram in Figure 35 shows a top level view of the individual power blocks.

SEL1 and SEL2 pins allow users to disable power blocks in order to reduce switching losses in light load applications. Depending on the state of these pins the ISL70003SEH can operate with 2, 4, or 10 active power blocks and also be placed in a sleep mode.

Each power block has a power supply input pin, PVINx, a phase output pin, LXx and a power supply ground pin, PGNDx. All PVINx pins must be connected to a common power supply rail and all PGNDx pins must be connected to a common ground. LXx pins should be connected to the output inductor based on the required load current and the state of the SEL1, SEL2 pins, but must include the LX5 and LX6 pins. The unused LXx pins should be left unconnected.

Scaled pilot devices associated with power blocks 5 and 6 provide current feedback for overcurrent detection and the IMON current monitor feature. Power blocks 5 and 6 must be connected to the output inductor at all times for proper operation.

Initialization

The ISL70003SEH initializes based on the state of the EN input and POR input. Successful initialization prompts a soft-start interval and the regulator begins slowly ramping the output voltage. Once the commanded output voltage is within the proper window of operation, the power-good signal changes state from low to high indicating proper regulator operation.

Enable

The EN pin accepts TTL/CMOS logic input as described in the Electrical Specifications table on page 9. When the voltage on the EN pin exceeds its logic rising threshold, the controller monitors the POR voltage before initiating the soft-start function for the PWM regulator. When EN is pulled low, the device enters shutdown mode and the supply current drops to a typical value of 1.5mA. All internal power devices are held in a high-impedance state while in shutdown mode. Due to the internal 5V clamp, the EN pin should be driven no higher than 5V or excessive leakage current may be seen on the pin. In standalone applications the EN pin may be tied to an input voltage >5V through a 50kΩ resistor to minimize the current into the EN pin. The current should not be allowed to exceed 160µA at any operating voltage.

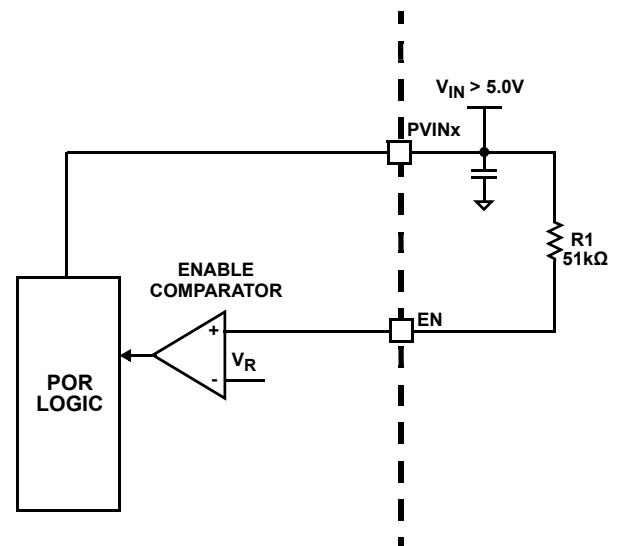

FIGURE 36. ENABLE TO V_{IN} FOR >5.0 INPUT VOLTAGE

Power on Reset

After the EN input requirements are met, the ISL70003SEH remains in shutdown until the voltage at the POR pin rises above its threshold. The POR circuitry prevents the controller from attempting to soft-start before sufficient bias is present at the PVINx pins.

As shown in Figure 37 on page 18, the POR circuit features a comparator type input. The POR circuit allows the level of the input voltage to precisely gate the turn-on/turn-off of the regulator. An internal I_{POR} current sink with a typical value of 12µA is only active when the voltage on the POR pin is below the enable threshold so it can pull the POR pin low. As V_{IN} rises, the POR enable level is set by the resistor divider (R_1 and R_2) from V_{IN} and the internal sink current source, I_{POR} .

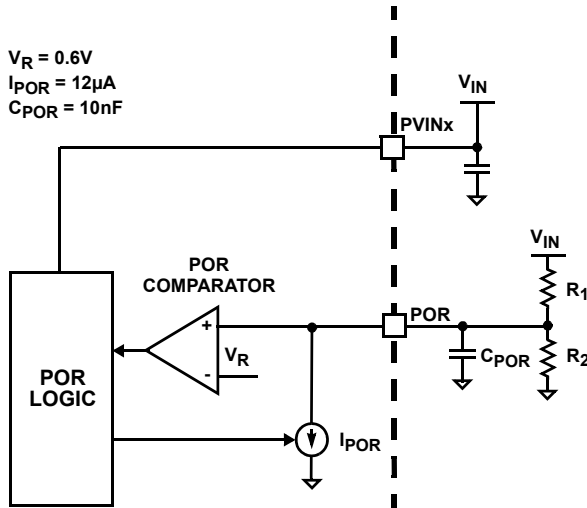

FIGURE 37. POR CIRCUIT

Equation 2 defines the relationship between the resistor divider, sink current and POR rising level (V_{PORR}).

$$V_{PORR} = V_R \cdot \left[1 + \frac{R_1}{R_2} \right] + I_{POR} \cdot R_1 \quad (\text{EQ. 2})$$

Once the voltage at the POR pin reaches the enable threshold, the I_{POR} current sink turns off.

With the part enabled and the I_{POR} current sink off, the falling level (V_{PORF}) is set by the resistor divider network and is defined by Equation 3.

$$V_{PORF} = V_R \cdot \left[1 + \frac{R_1}{R_2} \right] \quad (\text{EQ. 3})$$

The difference between the POR rising and falling levels provides adjustable hysteresis so that noise on V_{IN} does not interfere with the enabling or disabling of the regulator.

Soft-Start

The ISL70003SEH soft-start function uses an internal current source and an external capacitor to reduce stresses and surge current during start-up.

Once the POR and enable circuits are satisfied, the regulator waits 32 clock cycles and then initiates a soft-start. Figure 38 shows that the soft-start circuit clamps the error amplifier reference voltage to the voltage on an external soft-start capacitor connected to the SS pin. The soft-start capacitor is charged by an internal I_{SS} current source. As the soft-start capacitor is charged, the output voltage slowly ramps to the set point determined by the reference voltage and the feedback network. Once the voltage on the SS pin is equal to the internal reference voltage, the soft-start interval is complete. The soft-start output ramp interval is defined in Equation 4 and is adjustable from approximately 2ms to 200ms. The value of the soft-start capacitor, C_{SS} , should range from 82nF to 8.2µF, inclusive. The peak in-rush current can be computed from Equation 5. The soft-start interval should be selected long enough to insure that the peak in-rush current plus the peak

output load current does not exceed the overcurrent trip level of the regulator.

$$t_{SS} = C_{SS} \cdot \frac{V_{REF}}{I_{SS}} \quad (\text{EQ. 4})$$

$$I_{INRUSH} = C_{OUT} \cdot \frac{V_{OUT}}{t_{SS}} \quad (\text{EQ. 5})$$

The soft-start capacitor is immediately discharged by a 3.0Ω resistor whenever POR conditions are not met or EN is pulled low. The soft-start discharge time is equal to 256 clock cycles.

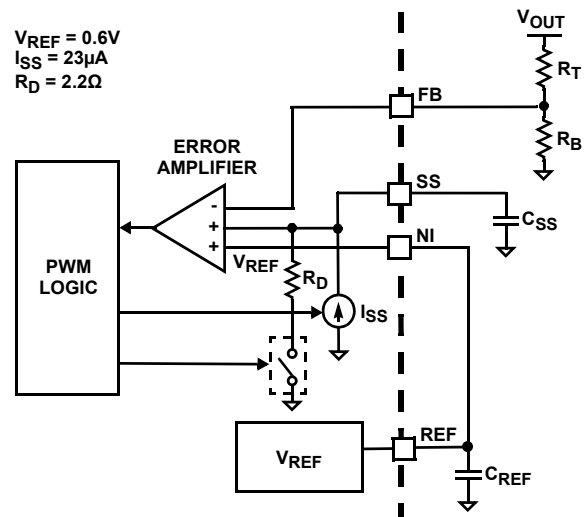

FIGURE 38. SOFT-START CIRCUIT

Power-Good

A power-good indicator is the final step of initialization. After a successful soft-start, the PGOOD pin releases and the voltage rises with an external pull-up resistor. The power-good signal transitions low immediately when the EN pin is pulled low.

The PGOOD pin is an open-drain logic output and can be pulled up to any voltage from 0V to 13.2V. The pull-up resistor should have a nominal value from 1kΩ to 10kΩ. The PGOOD pin should be bypassed to DGND with a 10nF ceramic capacitor to mitigate SEE.

Fault Monitoring and Protection

The ISL70003SEH actively monitors the output voltage and current to detect fault conditions. Fault conditions trigger protective measures to prevent damage to the regulator and the external load device. One common power-good indication signal is provided for linking to external system monitors. The schematic in Figure 39 on page 19 outlines the interaction between the fault monitors and the power-good signal.

Undervoltage and Overvoltage Monitor

The power-good pin (PGOOD) is an open-drain logic output which indicates that the converter is operating properly and the output voltage is within a set window. The undervoltage (UV) and overvoltage (OV) comparators create the output voltage window.

The power-good circuitry monitors the FB pin and compares it to the rising and falling thresholds shown in the "Electrical

Specifications” table on [page 11](#). If the feedback voltage exceeds the typical rising limit of 111% of the reference voltage, the PGOOD pin pulls low. The PGOOD pin continues to pull low until the feedback voltage falls to a typical of 107.5% of the reference voltage. If the feedback voltage drops below a typical of 89% of the reference voltage, the PGOOD pin pulls low. The PGOOD pin continues to pull low until the feedback voltage rises to a typical 92.5% of the reference voltage. The PGOOD pin then releases and signals the return of the output voltage within the power-good window

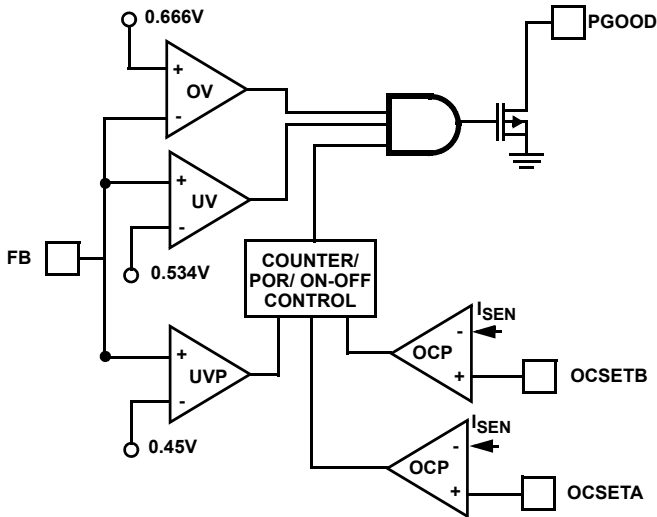

FIGURE 39. POWER-GOOD AND PROTECTION CIRCUITRY

Undervoltage Protection

A hysteretic comparator monitors the FB pin of the regulator. The feedback voltage is compared to an undervoltage threshold that is a fixed percentage of the reference voltage, typically 75%. Once the comparator trips, indicating a valid undervoltage condition, an undervoltage counter increments. The counter is reset if the feedback voltage rises back above the undervoltage threshold plus a specified amount of hysteresis outlined in the “Electrical Specifications” table on [page 11](#). If there are 4 consecutive undervoltage detections the counter will overflow and the undervoltage protection logic shuts down the regulator, pulling PGOOD low.

After the regulator shuts down, it enters a delay interval, approximately equivalent to 512 clock cycles plus 1 soft-start intervals, allowing the device to cool. The undervoltage counter is reset entering the delay interval. The protection logic initiates a normal soft-start once the delay interval ends. If the output successfully soft-starts, the power-good signal goes high and normal operation continues. If undervoltage conditions continue to exist during the soft-start interval, the undervoltage counter must overflow before the regulator shuts down again. This hiccup mode continues indefinitely until the output soft-starts successfully.

Overcurrent Protection

A pilot device integrated into the PMOS transistor of Power Blocks 5 and 6 sample the current each cycle. This current feedback is scaled and compared to an overcurrent threshold based on the resistor value tied from pins OCSETA and OCSETB to AGND.

Upon detection of an overcurrent condition, the upper MOSFET will be immediately turned off and will not be turned on again until the next switching cycle. Upon detection of the initial overcurrent condition, the overcurrent fault counter is set to 1. If, on the subsequent cycle, another overcurrent condition is detected, the OC fault counter will increment, however, if the sampled current falls below the threshold the counter is reset. If there are 4 sequential OC fault detections, the counter will overflow and the regulator will be shutdown under an overcurrent fault condition, pulling PGOOD low.

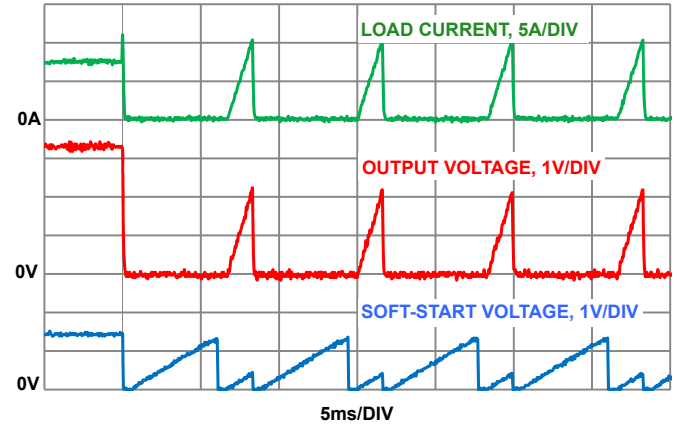

FIGURE 1. OVERCURRENT BEHAVIOR IN HICCUP MODE

After the regulator shuts down, it enters a delay interval, allowing the device to cool. The delay interval is approximately equal to 512 clock cycles plus 1 soft-start intervals. The overcurrent counter is reset entering the delay interval. The protection logic initiates a normal soft-start once the delay interval ends. If the output successfully soft-starts, the power-good signal goes high and normal operation continues. If overcurrent conditions continue to exist during the soft-start interval, the overcurrent counter must overflow before the regulator shutdowns the output again. This hiccup mode continues indefinitely until the output soft-starts successfully (see [Figure 1](#)).

Application Information

Voltage Feed-forward

Feed-forward is used to maintain a constant modulator gain and achieve optimum loop response over a wide input voltage range. A resistor from PVINx to RTCT and a capacitor from RTCT to PGNDx are used to adjust the amplitude of the sawtooth ramp proportional to the input voltage. The capacitor value must be chosen so that it is large enough for mitigation of single event transients but low enough for the internal MOSFET device to pull the pin to ground. The following table gives the recommended values for R_T and C_T for a given switching frequency. These values will achieve a constant modulator gain across the complete input voltage range.

FSEL STATE	f_{SW} (kHz)	R_T (k Ω)	C_T (pF)	MODULATOR GAIN (TYP)
0	500	22	370	5
1	300	36	370	4.8

Switching Frequency Selection

There are a number of variables to consider when choosing the switching frequency. A high switching frequency increases the switching losses but may lead to a decrease in output filter size. A lower switching frequency may increase efficiency but may lead to more output voltage ripple and increased output filter size.

On the ISL70003SEH the switching frequency is determined by the state of the TTL/CMOS compatible FSEL pin. A logic low will set the regulator to operate with a 500kHz switching frequency, while a logic high sets a 300kHz switching frequency.

Synchronization

The ISL70003SEH can be synchronized to an external clock with a frequency range of 500kHz \pm 15% or 300kHz \pm 15%, depending on the state of the FSEL pin.

The SYNC pin accepts the external clock signal and the regulator will be synchronized in phase with the external clock. During start-up the regulator will use its internal oscillator to regulate the output voltage. Once soft-start is complete and PGOOD is released, the regulator will synchronize to the external clock signal. This feature allows the ISL70003SEH regulator to be the power source to the external components that will be providing the external clock without the requirement that a signal must be present at the SYNC pin before start-up.

Output Voltage Selection

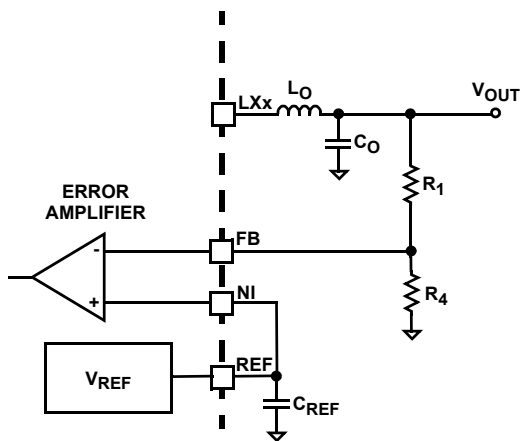

FIGURE 40. OUTPUT VOLTAGE SELECTION

The output voltage of the regulator can be programmed via an external resistor divider that is used to scale the output voltage relative to the reference voltage. The reference voltage and the non-inverting input to the error amplifier are not internally connected, therefore, for standalone applications the REF pin must be tied to the NI pin (see [Figure 40](#)). The REF pin should be bypassed to AGND with a 220nF ceramic capacitor to mitigate SEE. It should be noted that no current (sourcing or sinking) is available from the REF pin.

The output voltage programming resistor, R_4 , will depend on the value chosen for the feedback resistor R_1 and the desired output voltage of the regulator. The value for the feedback resistor is typically between 5k Ω and 25k Ω .

$$R_4 = \frac{R_1 \times 0.6V}{V_{OUT} - 0.6V} \quad (\text{EQ. 6})$$

If the output voltage desired is 0.6V, then R_4 is left unpopulated.

Setting the Overcurrent Protection Level

The ISL70003SEH features dual redundancy in the overcurrent detection circuitry, which helps avoid false overcurrent triggering due to single event effects. Two external resistors from pins OCSETA and OCSETB to AGND set the level of the overcurrent protection (OCP) trip point. The OCP circuit senses the peak current across a pilot device not the average current so it is important to determine the overcurrent trip point (I_{OCP}) greater than the maximum output continuous current (I_{MAX}) plus half the maximum inductor ripple current (ΔI).

Use [Equation 7](#) to determine the inductor ripple current:

$$\Delta I = \frac{V_{IN} - V_{OUT}}{f_{SW} \times L} \times D \quad (\text{EQ. 7})$$

Where f_{SW} is the switching frequency, L is the output inductor value and D is duty cycle. Once an I_{OCP} value is chosen that satisfies [Equation 8](#):

$$I_{OCP} \geq I_{MAX} + \frac{\Delta I}{2} \quad (\text{EQ. 8})$$

[Equation 9](#) may be used to determine the value of R_{OCSETA} and R_{OCSETB} with all 10 power blocks active.

$$R_{OCSET(A,B)} = \frac{36024}{I_{OCP}} \quad (\text{EQ. 9})$$

The minimum value for $R_{OCSET(A,B)}$ is 2.94k Ω which is equivalent to a 12.25A I_{OCP} level.

Disabling the Power Blocks

The ISL70003SEH offers two TTL/CMOS compatible power block select pins, SEL1 and SEL2, which form a two-bit logic input that are used to turn off the internal power blocks. Depending on the state of the SEL1 and SEL2 pins, the ISL70003SEH can operate with 2, 4 or 10 power blocks on or have all the outputs in a tri-state mode. This allows the designer to reduce switching losses in low current applications, where all power blocks are not needed to supply the load current. [Table 1 on page 20](#) compares the logic state of SEL1 and SEL2 with the current capability of the regulator and the number of active LX pins.

TABLE 1. LOGIC STATE COMPARISON

SEL2 STATE	SEL1 STATE	ACTIVE LX PINS	LOAD CAPABILITY ($T_J = +125^\circ\text{C}$)
0	0	All	6A
0	1	5, 6, 7, 8	2.4A
1	0	5, 6	1.2A
1	1	None	N/A

With both SEL pins in a logic high state, the ISL70003SEH is in a low power sleep mode where all outputs are tri-stated. Once the

logic activates the power blocks, the regulator ramps the output voltage to its set value within a soft-start interval, however, the device no longer goes through the preinitialization phase.

Transitions between the number of active LXx pins through the use of SEL1 and SEL2 should not be done while the part is operating. On the fly transitions will cause glitches on the output voltage which may exceed transient requirements. It is recommended to place the ISL70003SEH in standby mode, by pulling SEL1 and SEL2 HIGH, and then change the number of active LXx pins.

The overcurrent trip point scales depending on the number of active power blocks. Equation 10 may be used to determine the value of R_{OCSETA} and R_{OCSETB} when less than 10 power blocks are active:

$$R_{OCSET(A,B)} = \frac{3602.4 \times N}{I_{OCP}} \quad (\text{EQ. 10})$$

Where N is the number of active phases.

IMON Current Sense Output

The ISL70003SEH provides a current monitor function through IMON. Current monitoring informs designers if down stream loads are operating as expected. It is also useful in the prototype and debug phase of the design and during normal operation to measure the overall performance of a system. The IMON pin outputs a high speed analog current source that is proportional to the sensed peak current through the ISL70003SEH. In typical applications, a resistor R_{IMON} is connected to the IMON pin to convert the sensed current to voltage, V_{IMON} , which is proportional to the peak current, as shown in Equation 11:

$$V_{IMON} = 100 \times 10^{-6} \cdot \frac{I_{SAMPLE} \times R_{IMON}}{N} \quad (\text{EQ. 11})$$

where V_{IMON} is the voltage at the IMON pin, R_{IMON} is the resistor between the IMON pin and AGND, I_{SAMPLE} is the current through the converter at the time IMON samples the current, and N is the number of active power blocks. I_{SAMPLE} may be calculated from Equation 12.

$$I_{SAMPLE} = I_{LOAD} + \frac{\Delta I}{2} - \left(\Delta I \cdot \frac{t_{SAMPLE} \times f_{SW}}{(1-D)} \right) \quad (\text{EQ. 12})$$

Where t_{SAMPLE} is the time it takes the IMON circuitry to sample the current (300ns, max.), I_{LOAD} is the load current and ΔI is the inductor peak-to-peak ripple current as calculated in Equation 7.

A small capacitor should be placed between the IMON pin and AGND to reduce the noise impact and mitigate single event transients. If this pin is not used, it is best connected to VREFA. It is also acceptable to tie to GND through a resistor.

Figures 41 and 42 show the response of the IMON current monitor due to a load step with a $R_{IMON} = 10k\Omega$ and 100pF ceramic capacitor in parallel.

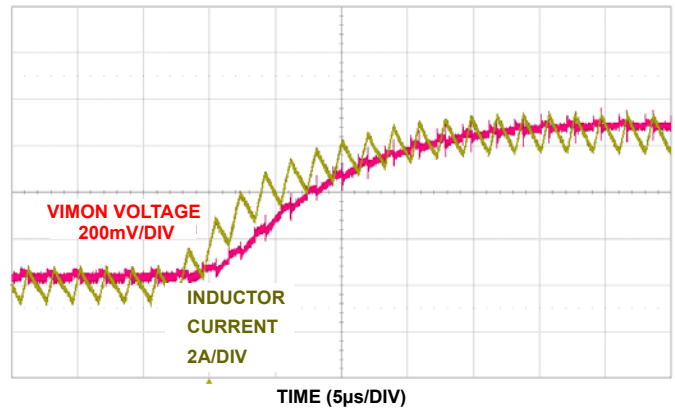

FIGURE 41. IMON RESPONSE TO 6A LOAD STEP

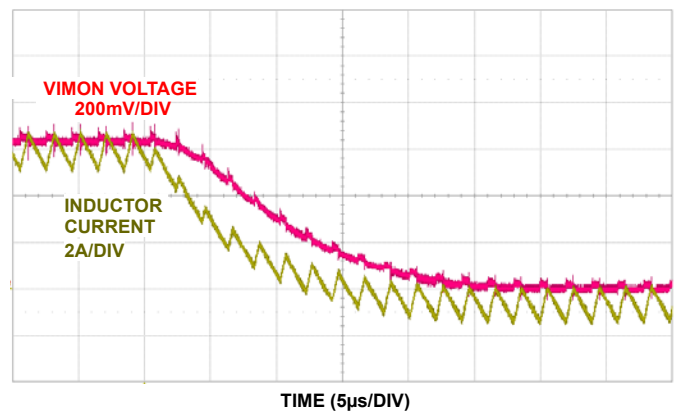

FIGURE 42. IMON RESPONSE TO 6A LOAD RELEASE

It is important to note that if the on time of the lower NMOS FET is shorter than the IMON current sense time (300ns max), the IMON output is tri-stated after 4 consecutive failed sense occurrences.

Diode Emulation

Diode Emulation (DE) allows for higher converter efficiency under light load situations. In DE mode, the low-side MOSFET conducts when the current is flowing from source to drain and does not allow reverse current, emulating a diode. As shown in Figure 43, when the LGATE signal is HIGH, the low-side MOSFET carries current, creating negative voltage on the phase node due to the voltage drop across the ON-resistance. When the DE pin is pulled HIGH, the ISL70003SEH will be in diode emulation mode and detect the zero current crossing of the inductor current and turn off the lower MOSFET to prevent the inductor current from reversing direction and creating unnecessary power loss. This ensures that discontinuous conduction mode (DCM) is achieved. Since diode emulation prevents the low-side MOSFET from sinking current, no negative spike at the output is generated during pre-biased startup when DE mode is active.

After a significantly fast load release transient, diode emulation will not allow the converter to bring the output voltage back down following the hump created by the inductor energy dump into the output capacitor bank. The ISL70003SEH overcomes this issue by monitoring the output of the error amplifier and allowing the

low-side MOSFET to turn on and sink the necessary current needed to properly regulate the output voltage. The same mechanism allows the converter to properly regulate the output voltage when starting into a prebiased condition where the prebias level is greater than the desired output voltage.

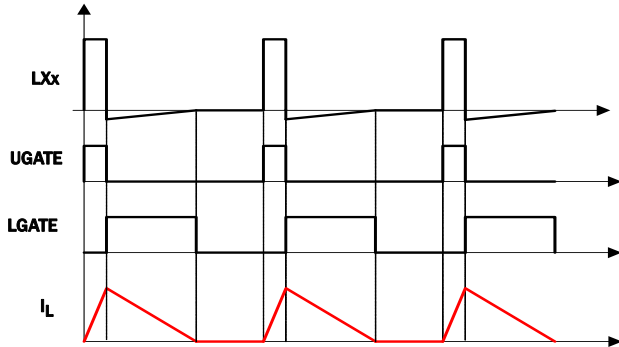

FIGURE 43. DIODE EMULATION

The DE pin is not intended to actively change states while the regulator is operating. If any part of the inductor current is below zero and the DE pin changes state there will be a glitch on the output voltage. However, if the state of the DE pin changes state when the inductor current is positive, no change in the operation of the regulator will be seen.

DDR Application

High through put Double Data Rate (DDR) memory ICs are replacing traditional memory ICs in space applications. A novel feature associated with this type of memory are the referencing and data bus termination techniques. These techniques employ a reference voltage, V_{REF} , that tracks the center point of V_{DDQ} and V_{SS} voltages, and an additional V_{TT} power source where all terminating resistors are connected. Despite the additional power source, the overall memory power consumption is reduced compared to traditional termination.

The added power source has a cluster of requirements that should be observed and considered. Due to the reduced differential thresholds of DDR memory, the termination power supply voltage, V_{TT} , closely tracks $V_{DDQ}/2$ voltage.

Another very important feature of the termination power supply is the capability to operate at equal efficiency in sourcing and sinking modes. The V_{TT} supply regulates the output voltage with the same degree of precision when current is flowing from the supply to the load, and when the current is diverted back from the load into the power supply.

The ISL70003SEH regulator possesses several important enhancements that allow reconfiguration for DDR memory applications. Two ISL70003SEH ICs will provide all three voltages required in a DDR memory compliant system.

DDR Configuration

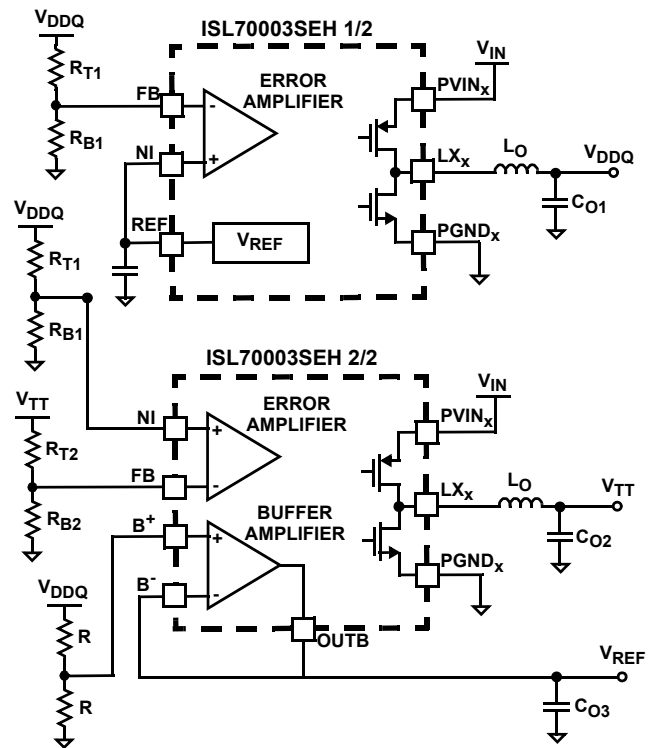

FIGURE 44. SIMPLIFIED DDR APPLICATION SCHEMATIC

In the DDR application presented in [Figure 44](#), an independent architecture is implemented to generate the voltages needed for DDR memory applications. Consequently, both V_{DDQ} and V_{TT} are derived independently from the main power source. The first regulator supplies the 2.5V for the V_{DDQ} voltage. The output voltage is set by external dividers R_{T1} and R_{B1} . The second regulator generates the V_{TT} rail typically = $V_{DDQ}/2$. The resistor divider network R_{T2} and R_{B2} are used to set the output voltage to 1.25V. The V_{DDQ} rail has an additional voltage divider network consisting of R_{T1} and R_{B1} , the midpoint is connected to the noninverting input pin of the V_{TT} regulator's error amplifier (NI), effectively providing a tracking function for the V_{TT} voltage.

The noninverting input of the buffer amplifier is connected to the center point of the external R/R divider from the V_{DDQ} output. The output of the buffer is tied back to the inverting input for unity gain configuration. The buffer output voltage serves as a 1.25V reference (V_{REF}) for the DDR memory chips. Sourcing capability of the buffer amplifier is 10mA typical (20mA max) and needs a minimum of 1 μ F load capacitance for stability.

Diode emulation mode of operation must be disabled on the V_{TT} regulator to allow sinking capability. In the event both channels are enabled simultaneously, the soft-start capacitor on the V_{DDQ} regulator should be two to three times larger than the soft-start capacitor on the V_{TT} regulator. This allows the V_{DDQ} regulator voltage to be the lowest input into the error amplifier of the V_{TT} regulator and dominate the soft-start ramp. However, if the V_{TT} regulator is enabled later than the V_{DDQ} , the soft-start capacitor can be any value based on design goals.

Each regulator has its own fault protections and must be individually configured. All the sink current on the V_{TT} regulator is provided by the VDDQ rail, the overcurrent protection on the VDDQ rail will limit the amount of current that the V_{TT} rail will sink.

When sinking current or at a no load condition, the inductor valley current is negative, see [Figure 27](#). During any time when the inductor valley current is negative and the ISL70003 is exposed to a heavy ion environment the abs max PVIN voltage must be $\leq 13.7V$, see [Note 5 on page 9](#).

SEL1 and SEL2 may be tied together and used to place the V_{TT} regulator in sleep mode, common to DDR applications. The outputs will be tri-stated, however the buffer amplifier is still active and the VREF voltage will be present even if the V_{TT} is in sleep mode. When SEL1 and SEL2 are asserted low, the V_{TT} regulator will ramp up the voltage. The ramp is controlled and timing is based on soft-start capacitor value.

Refer to [Figure 4 on page 8](#) for complete DDR power solution typical application circuit schematic.

Derating Current Capability

Most space programs issue specific derating guidelines for parts, but these guidelines take the pedigree of the part into account. For instance, a device built to MIL-PRF-38535, such as the ISL70003SEH, is already heavily derated from a current density standpoint. However, a mil-temp or commercial IC that is up-screened for use in space applications may need additional current derating to ensure reliable operation because it was not built to the same standards as the ISL70003SEH.

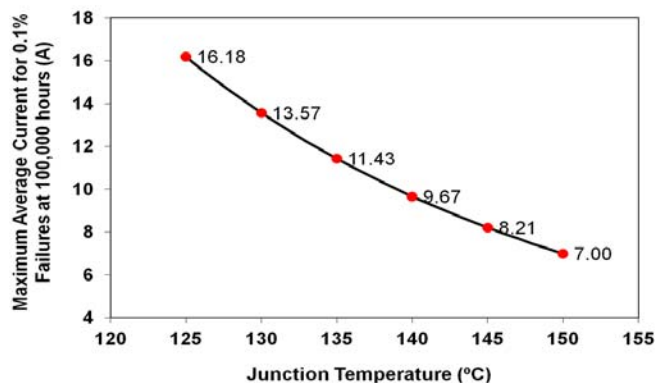

FIGURE 45. CURRENT vs TEMPERATURE

[Figure 45](#) shows the maximum average output current of the ISL70003SEH with respect to junction temperature. These plots take into account the worst-case current share mismatch in the power blocks and the current density requirement of MIL-PRF-38535 ($< 2 \times 10^5 \text{ A/cm}^2$). The plot clearly shows that the ISL70003SEH can handle 7A at +150 °C from a worst-case current density standpoint, but the part is rated to 3A. Therefore, no further current derating of the ISL70003SEH is needed.

General Design Guide

This design guide is intended to provide a high-level explanation of the steps necessary to design the power stage and feedback compensation network of a single phase power converter. It is assumed that the reader is familiar with many of the basic skills and techniques in switch mode power supply design. In addition to this guide, Intersil provides an evaluation board that includes schematic, bills of materials and board layout.

Output Inductor Selection

The output inductor is selected to minimize the converter's response time to a load transient and meet steady state output voltage ripple requirements. The inductor value determines the converter's inductor ripple current and the output voltage ripple is a function of the inductor ripple current. The output voltage ripple and the inductor ripple current are approximated by using [Equation 13](#):

$$\Delta I = \frac{V_{IN} - V_{OUT}}{f_{SW} \times L} \times \frac{V_{OUT}}{V_{IN}} \quad \Delta V_{OUT} = \Delta I \times ESR \quad (\text{EQ. 13})$$

Increasing the value of inductance reduces the ripple current and output voltage ripple. However, the large inductance values reduce the converter's response time to a load transient.

One of the parameters limiting the converter's response to a load transient is the time required to change the inductor current. The response time is the time required to slew the inductor current from an initial current value to the transient current level. During this interval the difference between the inductor current and the transient current level must be supplied by the output capacitor. Minimizing the response time can minimize the output capacitance required.

The response time to a transient is different for the application of load and the removal of load. [Equation 14](#), gives the approximate response time interval for application and removal of a transient load.

$$t_{RISE} = \frac{L \times I_{TRAN}}{V_{IN} - V_{OUT}} \quad t_{FALL} = \frac{L \times I_{TRAN}}{V_{OUT}} \quad (\text{EQ. 14})$$

Where I_{TRAN} is the transient load current step, t_{RISE} is the response time to the application of load, and t_{FALL} is the response time to the removal of load. The worst case response time can be either at the application or removal of load. Be sure to check both [Equations 13](#) and [14](#) at the minimum and maximum output levels for the worst case response time.

Output Capacitor Selection

An output capacitor is required to filter the inductor current and supply the load transient current. The filtering requirements are a function of the switching frequency and the ripple current. The load transient requirements are a function of the slew rate (di/dt) and the magnitude of the transient load current. These requirements are generally met with a mix of capacitors and careful layout.

High-frequency capacitors initially supply the transient and slow the current load rate seen by the bulk capacitors. The bulk filter

capacitor values are generally determined by the ESR (Effective Series Resistance) and voltage rating requirements rather than actual capacitance requirements.

High-frequency decoupling capacitors should be placed as close to the power pins of the load as physically possible. Be careful not to add inductance in the circuit board wiring that could cancel the usefulness of these low inductance components. The shape of the output voltage waveform during a load transient that represents the worst case loading conditions will ultimately determine the number of output capacitors and their type. When this load transient is applied to the converter, most of the energy required by the load is initially delivered from the output capacitors. This is due to the finite amount of time required for the inductor current to slew up to the level of the output current required by the load. This phenomenon results in a temporary dip in the output voltage. At the very edge of the transient, the Equivalent Series Inductance (ESL) of each capacitor induces a spike that adds on top of the existing voltage drop due to the Equivalent Series Resistance (ESR).

After the initial spike, attributable to the ESR and ESL of the capacitors, the output voltage experiences sag. This sag is a direct consequence of the amount of capacitance on the output.

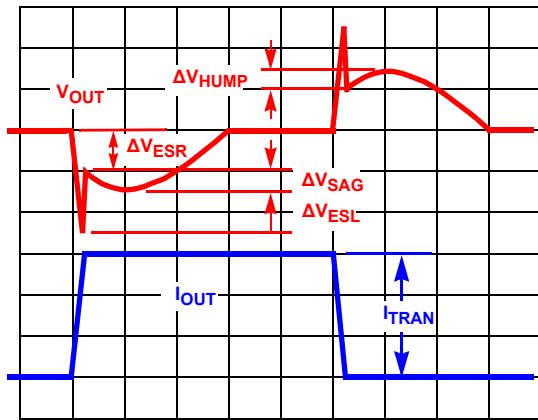

FIGURE 46. TYPICAL TRANSIENT RESPONSE

During the removal of the same output load, the energy stored in the inductor is dumped into the output capacitors. This energy dumping creates a temporary hump in the output voltage. This hump, as with the sag, can be attributed to the total amount of capacitance on the output. Figure 46 shows a typical response to a load transient.

The amplitudes of the different types of voltage excursions can be approximated using Equation 15.

$$\begin{aligned} \Delta V_{ESR} &= ESR^2 I_{tran} & \Delta V_{ESL} &= ESL^2 \frac{dI_{tran}}{dt} \\ \Delta V_{SAG} &= \frac{L_{OUT}^2 I_{tran}^2}{C_{OUT}^2 (V_{IN} - V_{OUT})} \\ \Delta V_{HUMP} &= \frac{L_{OUT}^2 I_{tran}^2}{C_{OUT}^2 V_{OUT}} \end{aligned} \quad (EQ. 15)$$

Where I_{tran} = Output Load Current Transient and C_{OUT} = Total Output Capacitance

In a typical converter design, the ESR of the output capacitor bank dominates the transient response. The ESR and the ESL are typically the major contributing factors in determining the output capacitance. The number of output capacitors can be determined by using Equation 16, which relates the ESR and ESL of the capacitors to the transient load step and the voltage limit (ΔV_o).

$$\text{Number of Capacitors} = \frac{ESL^2 \frac{dI_{tran}}{dt} + ESR^2 I_{tran}}{\Delta V_o} \quad (EQ. 16)$$

If ΔV_{SAG} and/or ΔV_{HUMP} are found to be too large for the output voltage limits, then the amount of capacitance may need to be increased. In this situation, a trade-off between output inductance and output capacitance may be necessary.

The ESL of the capacitors, which is an important parameter in the previous equations, is not usually listed in databooks. Practically, it can be approximated using Equation 17 if an Impedance vs Frequency curve is given for a specific capacitor:

$$ESL = \frac{1}{C(2\pi f_{res})^2} \quad (EQ. 17)$$

Where: f_{res} is the frequency where the lowest impedance is achieved (resonant frequency).

The ESL of the capacitors becomes a concern when designing circuits that supply power to loads with high rates of change in the current.

Input Capacitor Selection

Use a mix of input bypass capacitors to control the voltage overshoot across the MOSFETs. Use small ceramic capacitors for high-frequency decoupling and bulk capacitors to supply the current needed each time the upper MOSFET turns on. Place the small ceramic capacitors physically close to the MOSFETs and between the drain of the upper MOSFET and the source of the lower MOSFET.

The important parameters for the bulk input capacitance are the voltage rating and the RMS current rating. For reliable operation, select bulk capacitors with voltage and current ratings above the maximum input voltage and largest RMS current required by the circuit. Their voltage rating should be at least 1.25x greater than the maximum input voltage, while a voltage rating of 1.5x is a conservative guideline. For most cases, the RMS current rating requirement for the input capacitor of a buck regulator is approximately 1/2 the DC load current.

The maximum RMS current through the input capacitors may be closely approximated using Equation 18:

$$\sqrt{\frac{V_{OUT}}{V_{IN}} \left(I_{OUT_MAX}^2 \left(1 - \frac{V_{OUT}}{V_{IN}} \right) + \frac{1}{12} \left(\frac{V_{IN} - V_{OUT}}{Lx f_{OSC}} \times \frac{V_{OUT}}{V_{IN}} \right)^2 \right)} \quad (EQ. 18)$$

For surface mount designs, solid tantalum capacitors can be used, but caution must be exercised with regard to the capacitor surge current rating. These capacitors must be capable of handling the surge current at power-up. Some capacitor series available from reputable manufacturers are surge current tested.

Feedback Compensation

Figure 47 highlights the voltage-mode control loop for a synchronous rectified buck converter. The output voltage (V_{OUT}) is regulated to the reference voltage level. The error amplifier output (V_{EA}) is compared with the oscillator (OSC) triangular wave to provide a pulse-width modulated (PWM) wave with an amplitude of V_{IN} at the PHASE node. The PWM wave is smoothed by the output filter (L_O and C_O).

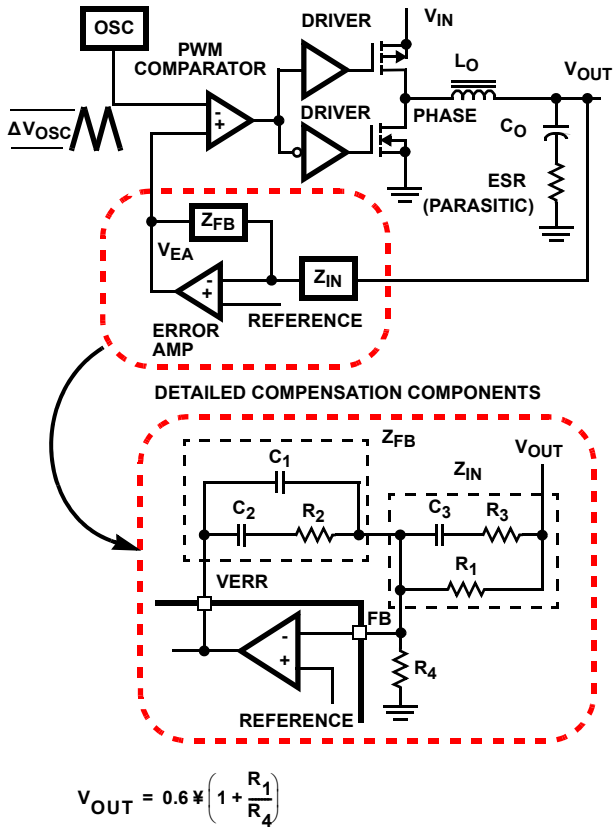

FIGURE 47. VOLTAGE-MODE BUCK CONVERTER COMPENSATION

The modulator transfer function is the small-signal transfer function of V_{OUT}/V_{EA} . This function is dominated by a DC Gain and the output filter (L_O and C_O), with a double pole break frequency at f_{LC} and a zero at f_{ESR} . The DC gain of the modulator is simply the input voltage (V_{IN}) divided by the peak-to-peak oscillator voltage ΔV_{OSC} . The ISL70003SEH incorporates a feed-forward loop that accounts for changes in the input voltage. This maintains a constant modulator gain of 5, typical.

Modulator Break Frequency Equations

$$f_{LC} = \frac{1}{2\pi \times \sqrt{L_O} \times C_O} \quad f_{ESR} = \frac{1}{2\pi \times ESR \times C_O} \quad (EQ. 19)$$

The compensation network consists of the error amplifier and the impedance networks Z_{IN} and Z_{FB} . The goal of the compensation network is to provide a closed loop transfer function with the highest OdB crossing frequency (f_{0dB}) and adequate phase margin. Phase margin is the difference between the closed loop phase at f_{0dB} and 180° .

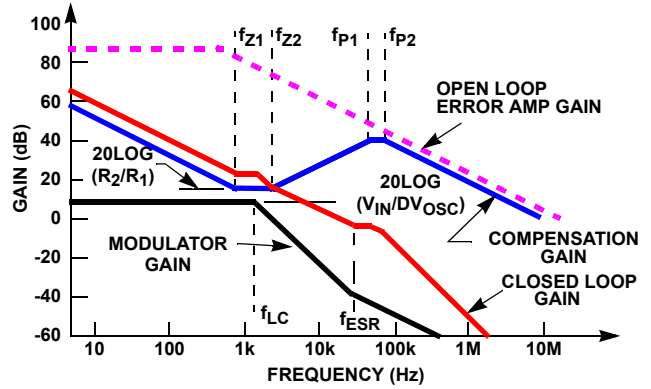

FIGURE 48. ASYMPTOTIC BODE PLOT OF CONVERTER GAIN

Equation 20 relates the compensation network's poles, zeros and gain to the components (R_1, R_2, R_3, C_1, C_2 and C_3) in Figure 47. Use these guidelines for locating the poles and zeros of the compensation network:

1. Pick Gain (R_2/R_1) for desired converter bandwidth.
2. Place 1st Zero Below Filter's Double Pole ($\sim 75\% f_{LC}$).
3. Place 2nd Zero at Filter's Double Pole.
4. Place 1st Pole at the ESR Zero.
5. Place 2nd Pole at Half the Switching Frequency.
6. Check Gain against Error Amplifier's Open-Loop Gain.
7. Estimate Phase Margin - Repeat if Necessary.

Compensation Break Frequency Equations

$$f_{z1} = \frac{1}{2\pi \times R_2 \times C_1} \quad f_{p1} = \frac{1}{2\pi \times R_2 \times \left(\frac{C_1 \times C_2}{C_1 + C_2} \right)}$$

$$f_{z2} = \frac{1}{2\pi \times (R_1 + R_3) \times C_3} \quad f_{p2} = \frac{1}{2\pi \times R_3 \times C_3} \quad (EQ. 20)$$

Figure 48 shows an asymptotic plot of the DC/DC converter's gain vs frequency. The actual Modulator Gain has a high gain peak due to the high Q factor of the output filter and is not shown in Figure 48. Using the guidelines provided should give a Compensation Gain similar to the curve plotted. The open loop error amplifier gain bounds the compensation gain. Check the compensation gain at f_{p2} with the capabilities of the error amplifier. The Closed Loop Gain is constructed on the graph of Figure 48 by adding the Modulator Gain (in dB) to the Compensation Gain (in dB). This is equivalent to multiplying the modulator transfer function to the compensation transfer function and plotting the gain. The compensation gain uses external impedance networks Z_{FB} and Z_{IN} to provide a stable, high bandwidth (BW) overall loop. A stable control loop has a gain crossing with -20dB/decade slope and a phase margin greater than $+45^\circ$. Include worst case component variations when determining phase margin. A more detailed explanation of voltage mode control of a buck regulator can be found in Tech Brief TB417, entitled "Designing Stable Compensation Networks for Single Phase Voltage Mode Buck Regulators".

PCB Design

PCB design is critical to high-frequency switching regulator performance. Careful component placement and trace routing are necessary to reduce voltage spikes and minimize undesirable voltage drops. Selection of a suitable thermal interface material is also required for optimum heat dissipation and to provide lead strain relief.

PCB Plane Allocation

A minimum of four layers of two ounce copper are recommended. Layer 2 should be a dedicated ground plane with all critical component ground connections made with vias to this layer. Layer 3 should be a dedicated power plane split between the input and output power rails. Layers 1 and 4 should be used primarily for signals, but can also provide additional power and ground islands as required.

PCB Component Placement

Components should be placed as close as possible to the IC to minimize stray inductance and resistance. Prioritize the placement of bypass capacitors on the pins of the IC in the order shown: REF, SS, AVDD, DVDD, PVINx (high-frequency capacitors), EN, PGOOD, PVINx (bulk capacitors).

Locate the output voltage resistive divider as close as possible to the FB pin of the IC. The top leg of the divider should connect directly to the output of the inductor via a kelvin trace and the bottom leg of the divider should connect directly to AGND. This AGND connection should also be a kelvin trace connected to the closest ground to the inductor output. The junction of the resistive divider should connect directly to the FB pin.

If desired place a Schottky clamp diode as close as possible to the LXx and PGNDx pins of the IC. A small series R-C snubber connected from the LXx pins to the PGNDx pins may be used to damp high-frequency ringing on the LXx pins if desired.

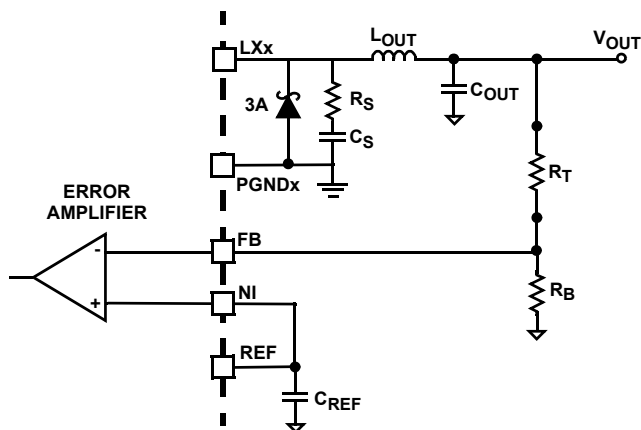

FIGURE 49. SCHOTTKY DIODE AND R-C SNUBBER

LX Connection

Use a small island of copper to connect the LXx pins of the IC to the output inductor on layers 1 and 4. Void the copper on layers 2 and 3 adjacent to the island to minimize capacitive coupling to the power and ground planes. Place most of the island on layer 4 to minimize the amount of copper that must be voided from the ground plane (layer 2).

Keep all other signal traces as short as possible.

Thermal Management for Ceramic Package

For optimum thermal performance, place a pattern of vias on the top layer of the PCB directly underneath the IC. Connect the vias to the plane which serves as a heatsink. To ensure good thermal contact, thermal interface material such as a Sil-Pad or thermally conductive epoxy should be used to fill the gap between the vias and the bottom of the IC of the ceramic package.

Lead Strain Relief

The package leads protrude from the bottom of the package and the leads need forming to provide strain relief. On the ceramic bottom package R64.A, the Sil-pad or epoxy maybe be used to fill the gap left between the PCB board and the bottom of the package when lead forming is completed. On the heatsink option of the package R64.C, the lead forming should be made so that the bottom of the heatsink and the formed leads are flush.

Heatsink Mounting Guidelines

The R64.C package option has a heatsink mounted on the underside of the package. The following JESD-51x series guidelines may be used to mount the package:

1. Place a thermal land on the PCB under the heatsink.
2. The land should be approximately the same size as to 1mm larger than the 10.16x10.16mm heatsink.
3. Place an array of thermal vias below the thermal land.
 - Via array size: $\sim 9 \times 9 = 81$ thermal vias.
 - Via diameter: ~ 0.3 mm drill diameter with plated copper on the inside of each via.
 - Via pitch: ~ 1.2 mm.
 - Vias should drop to and contact as much metal area as feasible to provide the best thermal path.

Heatsink Electrical Potential

The heatsink is connected to pin 50 within the package; thus the PCB design and potential applied to pin 50 will therefore define the heatsink potential.

Heatsink Mounting Materials

In the case of electrically conductive mounting methods (conductive epoxy, solder, etc) the thermal land, vias and connected plane(s) below must be the same potential as pin 50.

In the case of electrically non-conductive mounting methods (non-conductive epoxy), the heatsink and pin 50 could have different electrical potential than the thermal land, vias and connected plane(s) below.

ISL70003SEH

Package Characteristics

Weight of Packaged Device

1.43 Grams (typical) - R64.A Package
 2.65 Grams (typical) - R64.C Package

Lid Characteristics

Finish: Gold
 Lid Potential: PGND

Die Characteristics

Die Dimensions

8300µm x 8300µm (327 mils x 327 mils)
 Thickness: 300µm ± 25.4µm (12 mils ± 1 mil)

Interface Materials

GLASSIVATION

Type: Silicon Oxide and Silicon Nitride
 Thickness: 0.3µm ± 0.03µm to 1.2µm ± 0.12µm

TOP METALLIZATION

Type: AlCu (99.5%/0.5%)
 Thickness: 2.7µm ± 0.4µm

BACKSIDE FINISH

Silicon

PROCESS

0.6µm BiCMOS Junction Isolated

ASSEMBLY RELATED INFORMATION

Substrate and Lid Potential

PGND

ADDITIONAL INFORMATION

Worst Case Current Density

$< 2 \times 10^5 \text{ A/cm}^2$

Transistor Count

26,144

Metallization Mask Layout

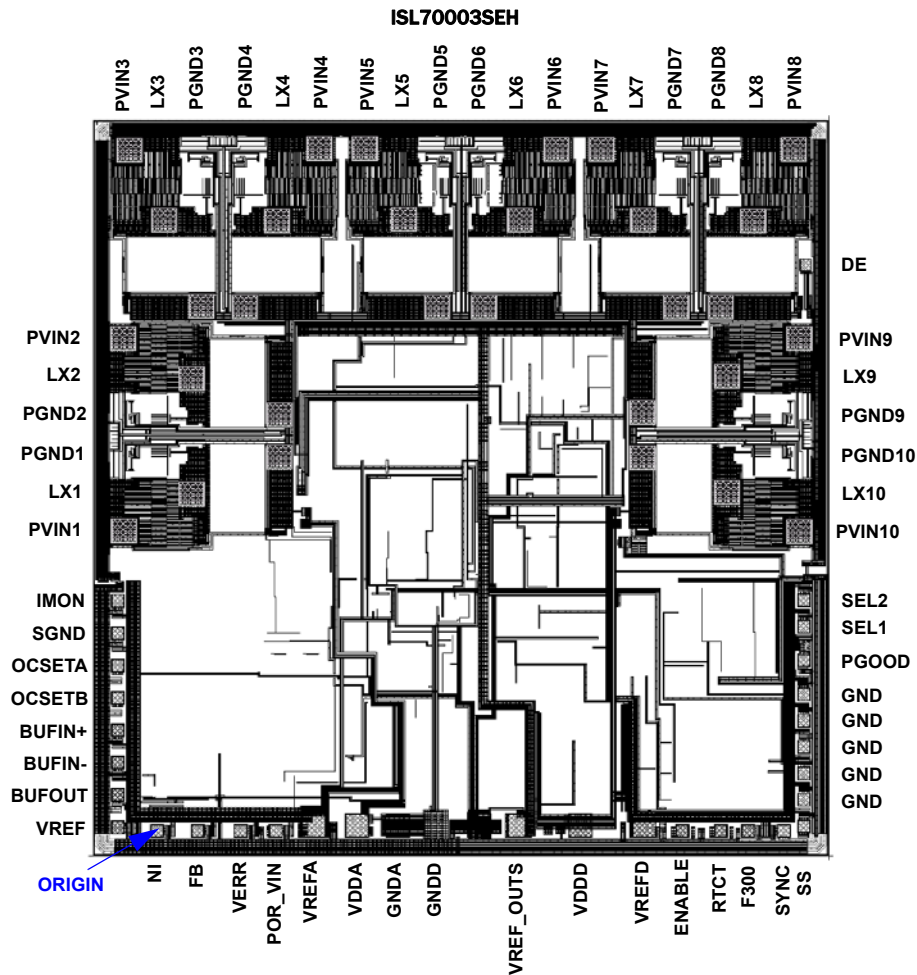

ISL70003SEH

TABLE 2. LAYOUT X-Y COORDINATES

PAD NAME	PAD NUMBER	X (µm)	Y (µm)	dX (µm)	dY (µm)	BOND WIRES SIZE (0.001")
NI	1	0	0	135	135	1.5
FB	2	452	0	135	135	1.5
Verr	3	929	0	135	135	1.5
POR_VIN	4	1371	0	135	135	1.5
VrefA	5	1854	58	254	254	3
VDDA	6	2577	60	254	254	3
GNDA	7	3104	60	254	254	3
GNDD	8	3589	60	254	254	3
Vref OUTs	9	4035	60	254	254	3
VDDD	10	4713	60	254	254	3
VrefD	11	5420	60	254	254	3
ENABLE	12	5846	0	135	135	1.5
RtCt	13	6274	0	135	135	1.5
F300	14	6579	0	135	135	1.5
Sync	15	6976	0	135	135	1.5
SS Cap	16	7201	51	135	135	1.5
TDI	17	7201	345	135	135	1.5
Zap	18	7201	639	135	135	1.5
TD0	19	7201	934	135	135	1.5
TST Trim	20	7201	1228	135	135	1.5
TCLK	21	7201	1522	135	135	1.5
Pgood	22	7201	1902	135	135	1.5
SEL1	23	7201	2275	135	135	1.5
SEL2	24	7201	2569	135	135	1.5
PVin10	25	7140	3285	254	254	3
LX10	26	6350	3771	254	254	3
PGND10	27	5387	4179	254	254	3
PGND9	28	5387	4625	254	254	3
LX9	29	6350	5033	254	254	3
PVin9	30	7140	5518	254	254	3
Deon	31	7220	6303	135	135	1.5
PVin8	32	7140	7578	254	254	3
LX8	33	6655	6788	254	254	3
PGND8	34	6247	5825	254	254	3
PGND7	35	5801	5825	254	254	3
LX7	36	5393	6788	254	254	3
PVin7	37	4908	7578	254	254	3
PVin6	38	4497	7578	254	254	3
LX6	39	4011	6788	254	254	3

ISL70003SEH

TABLE 2. LAYOUT X-Y COORDINATES (Continued)

PAD NAME	PAD NUMBER	X (μm)	Y (μm)	dX (μm)	dY (μm)	BOND WIRES SIZE (0.001")
PGND6	40	3603	5825	254	254	3
PGND5	41	3157	5825	254	254	3
LX5	42	2749	6788	254	254	3
PVin5	43	2264	7578	254	254	3
PVin4	44	1853	7578	254	254	3
LX4	45	1367	6788	254	254	3
PGND4	46	960	5825	254	254	3
PGND3	47	514	5825	254	254	3
LX3	48	106	6788	254	254	3
PVin3	49	-379	7578	254	254	3
PVIN2	50	-379	5518	254	254	3
LX2	51	411	5033	254	254	3
PGND2	52	1374	4625	254	254	3
PGND1	53	1374	4179	254	254	3
LX1	54	411	3771	254	254	3
PVin1	55	-379	3285	254	254	3
Imon	56	-438	2561	135	135	1.5
sgnd	57	-438	2201	135	135	1.5
OCSETA	58	-438	1841	135	135	1.5
OCSETB	59	-438	1481	135	135	1.5
Buf IN +	60	-438	1121	135	135	1.5
Buf IN -	61	-438	761	135	135	1.5
Buf OUT	62	-438	401	135	135	1.5
Vref	63	-438	41	135	135	1.5

For additional products, see www.intersil.com/en/products.html

Intersil products are manufactured, assembled and tested utilizing ISO9001 quality systems as noted in the quality certifications found at www.intersil.com/en/support/qualandreliability.html

Intersil products are sold by description only. Intersil Corporation reserves the right to make changes in circuit design, software and/or specifications at any time without notice. Accordingly, the reader is cautioned to verify that data sheets are current before placing orders. Information furnished by Intersil is believed to be accurate and reliable. However, no responsibility is assumed by Intersil or its subsidiaries for its use; nor for any infringements of patents or other rights of third parties which may result from its use. No license is granted by implication or otherwise under any patent or patent rights of Intersil or its subsidiaries.

For information regarding Intersil Corporation and its products, see www.intersil.com

Revision History

The revision history provided is for informational purposes only and is believed to be accurate, but not warranted. Please go to the web to make sure that you have the latest revision.

DATE	REVISION	CHANGE
February 6, 2015	FN8604.4	On page 6, added text in the FB, PVINx, SEL1, SEL2 and IMON pin descriptions. On page 7 corrected pin names in Figure 3. On page 8 corrected pin names in Figure 4. On page 9, updated Note 5 by adding "with any negative inductor current". On page 23, added the fifth paragraph under the DDR Configuration section. On page 26, added text to the second paragraph under "PCB Component Placement".
March 7, 2014	FN8604.3	Added new feedback link, updated Related Literature and updated About Intersil.
March 3, 2014	FN8604.2	Cosmetic edits throughout file.
December 20, 2013	FN8604.1	Initial Release.

About Intersil

Intersil Corporation is a leading provider of innovative power management and precision analog solutions. The company's products address some of the largest markets within the industrial and infrastructure, mobile computing and high-end consumer markets.

For the most updated datasheet, application notes, related documentation and related parts, please see the respective product information page found at www.intersil.com.

You may report errors or suggestions for improving this datasheet by visiting www.intersil.com/ask.

Reliability reports are also available from our website at www.intersil.com/support

Package Outline Drawing

R64.A

64 CERAMIC QUAD FLATPACK PACKAGE (CQFP)

Rev 5, 10/13

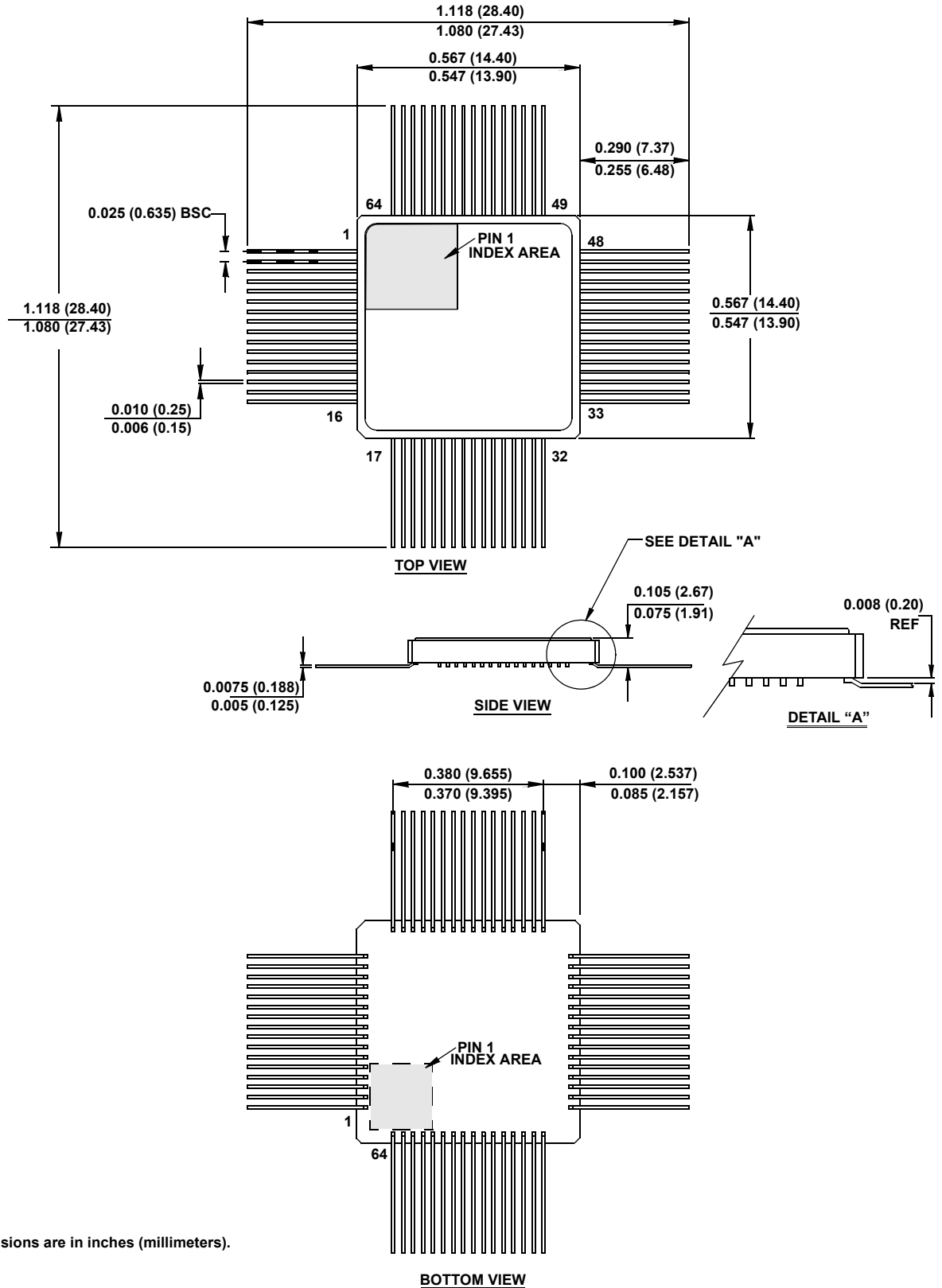

NOTE:

- All dimensions are in inches (millimeters).

Package Outline Drawing

R64.C

64 CERAMIC QUAD FLATPACK PACKAGE (CQFP) WITH BOTTOM HEATSINK

Rev 1, 10/13

